

DATA SHEET

SAA7185 Digital Video Encoder (DENC2)

Preliminary specification
Supersedes data of 1995 Jun 15
File under Integrated Circuits, IC02

1996 Jul 08

Digital Video Encoder (DENC2)

SAA7185

FEATURES

- CMOS 5 V device
- Digital PAL/NTSC encoder
- System pixel frequency 13.5 MHz
- Accepts MPEG decoded data
- 8-bit wide MPEG port
- Input data format Cb, Y, Cr etc. (CCIR 656)
- 16-bit wide YUV input port
- I²C-bus control or alternatively MPU parallel control port
- Encoder can be master or slave
- Programmable horizontal and vertical input synchronization phase
- Programmable horizontal sync output phase
- OSD overlay with Look-Up Tables (LUTs) 8 × 3 bytes
- Colour bar generator
- Line 21 Closed Caption encoder
- Cross-colour reduction
- DACs operating at 27 MHz with 10-bit resolution
- Controlled rise/fall times of output syncs and blanking
- Down-mode of DACs
- CVBS and S-Video output simultaneously
- PLCC68 package.



GENERAL DESCRIPTION

The SAA7185 encodes digital YUV video data to an NTSC, PAL CVBS or S-Video signal.

The circuit accepts CCIR compatible YUV data with 720 active pixels per line in 4 : 2 : 2 multiplexed formats, for example MPEG decoded data. It includes a sync/clock generator and on-chip Digital-to-Analog Converters (DACs).

The circuit is compatible to the DIG-TV2 chip family.

QUICK REFERENCE DATA

SYMBOL	PARAMETER	MIN.	TYP.	MAX.	UNIT
V _{DDA}	analog supply voltage	4.75	5.0	5.25	V
V _{DDD}	digital supply voltage	4.5	5.0	5.5	V
I _{DDA}	analog supply current	–	50	55	mA
I _{DDD}	digital supply current	–	140	170	mA
V _i	input signal voltage levels	TTL compatible			
V _{o(p-p)}	analog output signal voltages Y, C and CVBS without load (peak-to-peak value)	–	2	–	V
R _L	load resistance	80	–	–	Ω
ILE	LF integral linearity error	–	–	±2	LSB
DLE	LF differential linearity error	–	–	±1	LSB
T _{amb}	operating ambient temperature	0	–	+70	°C

Digital Video Encoder (DENC2)

SAA7185

ORDERING INFORMATION

TYPE NUMBER	PACKAGE		
	NAME	DESCRIPTION	VERSION
SAA7185WP	PLCC68	plastic leaded chip carrier; 68 leads	SOT188-2

BLOCK DIAGRAM

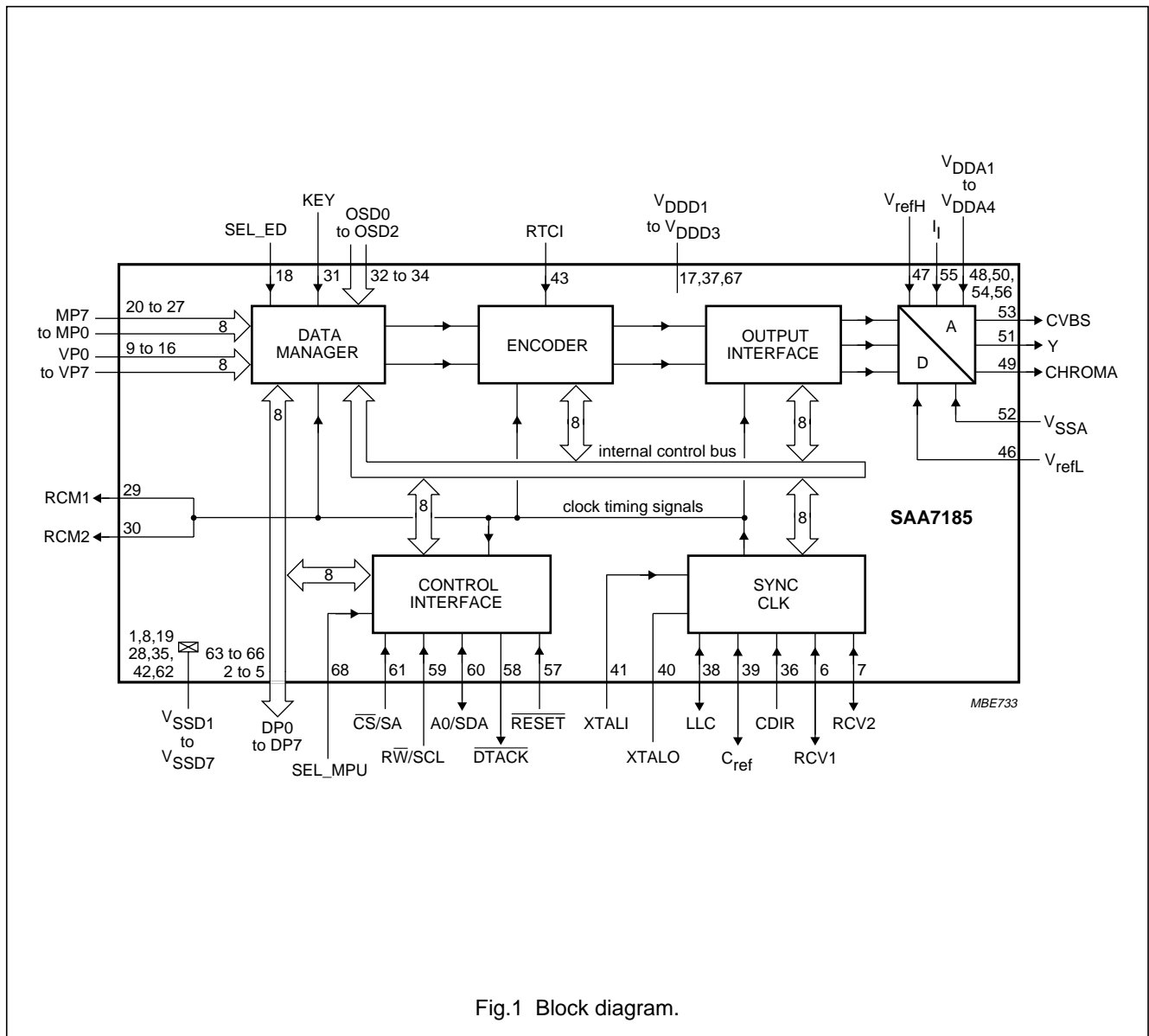

Fig.1 Block diagram.

Digital Video Encoder (DENC2)

SAA7185

PINNING

SYMBOL	PIN	DESCRIPTION
V _{SSD1}	1	digital ground 1
DP4	2	Upper 4 bits of the Data Port. If pin 68 (SEL_MPU) is HIGH, this is the data bus of the parallel MPU interface. If it is LOW, they are the UV lines of the Video Port.
DP5	3	
DP6	4	
DP7	5	
RCV1	6	Raster Control 1 for Video port. Depending on the synchronization mode, this pin receives/provides a VS/FS/FSEQ signal.
RCV2	7	Raster Control 2 for Video port. Depending on the synchronization mode, this pin receives/provides an HS/HREF/CBL signal.
V _{SSD2}	8	digital ground 2
VP0	9	Video Port. This is an input for CCIR 656 compatible, multiplexed video data. If the 16-bit DIG-TV2 format is used, this is the Y data.
VP1	10	
VP2	11	
VP3	12	
VP4	13	
VP5	14	
VP6	15	
VP7	16	
V _{DDD1}	17	digital supply voltage 1
SEL_ED	18	Select Encoder Data. Selects data either from MPEG port or from video port as encoder input.
V _{SSD3}	19	digital ground 3
MP7	20	MPEG Port. It is an input for CCIR 656 style multiplexed YUV data.
MP6	21	
MP5	22	
MP4	23	
MP3	24	
MP2	25	
MP1	26	
MP0	27	
V _{SSD4}	28	digital ground 4
RCM1	29	Raster Control 1 for MPEG port. This pin provides a VS/FS/FSEQ signal.
RCM2	30	Raster Control 2 for MPEG port. This pin provides an HS pulse for the MPEG decoder.
KEY	31	Key signal for OSD. It is active HIGH.
OSD0	32	On-Screen Display data. This is the index for the internal OSD look-up table.
OSD1	33	
OSD2	34	
V _{SSD5}	35	digital ground 5
CDIR	36	Clock direction. If the CDIR input is HIGH, the circuit receives a clock signal, otherwise LLC and CREF are generated by the internal crystal oscillator.
V _{DDD2}	37	digital supply voltage 2

Digital Video Encoder (DENC2)

SAA7185

SYMBOL	PIN	DESCRIPTION
LLC	38	Line-Locked Clock. This is the 27 MHz master clock for the encoder. The direction is set by the CDIR pin.
C _{ref}	39	Clock Reference signal. This is the clock qualifier for DIG-TV2 compatible signals.
XTALO	40	Crystal oscillator output (to crystal).
XTALI	41	Crystal oscillator input (from crystal). If the oscillator is not used, this pin should be connected to ground.
V _{SSD6}	42	digital ground 6
RTCI	43	Real Time Control Input. If the clock is provided by an SAA7151B, RTCI should be connected to the RTCO pin of the decoder to improve the signal quality.
AP	44	Test pin. Connect to digital ground for normal operation.
SP	45	Test pin. Connect to digital ground for normal operation.
V _{refL}	46	Lower reference voltage input for the DACs.
V _{refH}	47	Upper reference voltage input for the DACs.
V _{DDA1}	48	Analog positive supply voltage 1 for the DACs and output amplifiers.
CHROMA	49	Analog output of the chrominance signal.
V _{DDA2}	50	Analog supply voltage 2 for the DACs and output amplifiers.
Y	51	Analog output of the luminance signal.
V _{SSA}	52	Analog ground for the DACs and output amplifiers.
CVBS	53	Analog output of the CVBS signal.
V _{DDA3}	54	Analog supply voltage 3 for the DACs and output amplifiers.
I _I	55	Current input for the output amplifiers, connect via a 15 kΩ resistor to V _{DDA} .
V _{DDA4}	56	Analog supply voltage 4 for the DACs and output amplifiers.
RESET	57	Reset input, active LOW. After reset is applied, all outputs are in 3-state input mode. The I ² C-bus receiver waits for the start condition.
DTACK	58	Data acknowledge output of the parallel MPU interface, active LOW, otherwise high impedance.
RW/SCL	59	If pin 68 (SEL_MPU) is HIGH, this is the read/write signal of the parallel MPU interface, otherwise it is the I ² C-bus serial clock input.
A0/SDA	60	If pin 68 (SEL_MPU) is HIGH, this is the address signal of the parallel MPU interface, otherwise it is the I ² C-bus serial data input/output.
CS/SA	61	If pin 68 (SEL_MPU) is HIGH, this is the chip select signal of the parallel MPU interface, otherwise it is the I ² C-bus slave address select pin. LOW: slave address = 88H, HIGH = 8CH.
V _{SSD7}	62	digital ground 7
DP0	63	Lower 4 bits of the Data Port. If pin 68 (SEL_MPU) is HIGH, this is the data bus of the parallel MPU interface. If it is LOW, they are the UV lines of the Video Port.
DP1	64	
DP2	65	
DP3	66	
V _{DDD3}	67	digital supply voltage 3
SEL_MPU	68	Select MPU interface input. If it is HIGH, the parallel MPU interface is active, otherwise the I ² C-bus interface will be used.

Digital Video Encoder (DENC2)

SAA7185

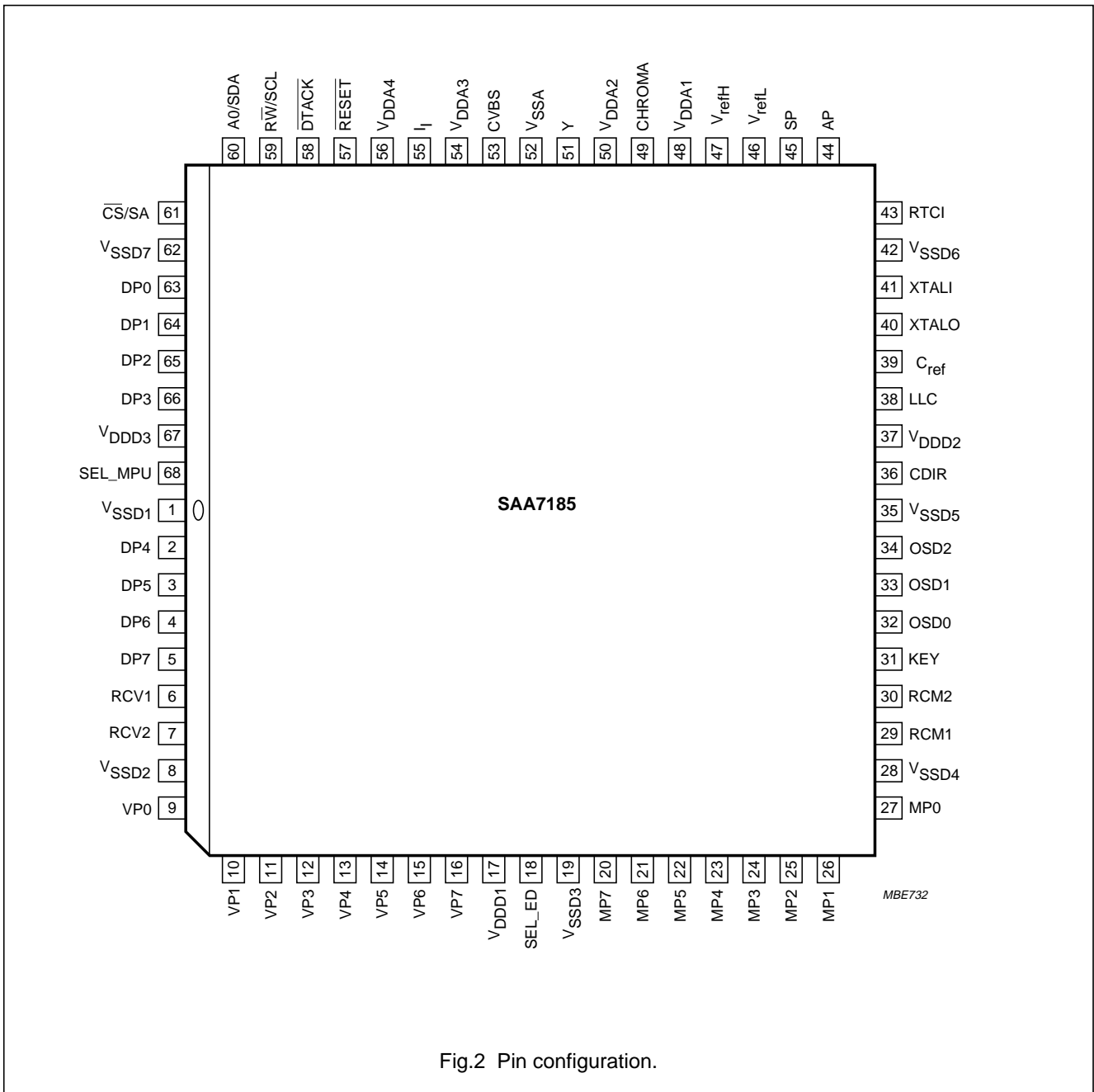

Digital Video Encoder (DENC2)

SAA7185

FUNCTIONAL DESCRIPTION

The digital MPEG-compatible Video Encoder (DENC2) encodes digital luminance and chrominance into analog CVBS and simultaneously S-Video (Y/C) signals. NTSC-M and PAL B/G standards also sub-standards are supported.

The basic encoder function consists of subcarrier generation and colour modulation also insertion of synchronization signals. Luminance and chrominance signals are filtered in accordance with the standard requirements RS-170-A and CCIR 624.

For ease of analog post filtering the signals are twice oversampled with respect to pixel clock before digital-to-analog conversion.

For total filter transfer characteristics see Figs 3, 4, 5 and 6. The DACs are realized with full 10-bit resolution. The encoder provides three 8-bit wide data ports, that serve different applications.

The MPEG Port (MP) and the Video Port (VP) accept 8 lines multiplexed Cb-Y-Cr data.

The Video Port (VP) is also able to handle DIG-TV2 family compatible 16-bit YUV signals. In this event, the Data Port (DP) is used for the U/V components.

The Data Port can handle the data of an 8-bit wide microprocessor interface, alternatively.

The 8-bit multiplexed Cb-Y-Cr formats are CCIR 656 (D1 format) compatible, but the SAV, EAV etc. codes are not decoded.

A crystal-stable master clock (LLC) of 27 MHz, which is twice the CCIR line-locked pixel clock of 13.5 MHz, needs to be supplied externally. Optionally, a crystal oscillator input/output pair of pins and an on-chip clock driver is provided. Additionally, a DMSD2 compatible clock interface, using C_{ref} (input or output) and RTC (see "*data sheet SAA7151B*") is available.

The DENC2 synthesizes all necessary internal signals, colour subcarrier frequency, and synchronization signals, from that clock. DENC2 is always timing master for the MPEG Port (MP), but it can additionally be configured as master or slave for the Video Port (VP).

The IC also contains Closed Caption and Extended Data Services Encoding (Line 21); it also supports OSD via KEY and three-bit overlay techniques by a 24×8 LUT.

The IC can be programmed via I²C-bus or 8-bit MPU interface, but only one interface configuration can be active at a time; if the 16-bit Video Port mode (VP and DP) is being used, only the I²C-bus interface can be selected.

A number of possibilities are provided for setting of different video parameters such as:

- black and blanking level control
- colour subcarrier frequency
- black variable burst amplitude etc.

During reset ($\overline{RESET} = LOW$) and after reset is released, all digital I/O stages are set to input mode. A reset forces the control interfaces to abort any running bus transfer and to set Register 3AH to contents 13H, Register 61H to contents 0X010101b, and Register 6CH to contents 00H. All other control registers are not influenced by a reset.

Data manager

In the Data manager, real time arbitration on the data stream to be encoded is performed.

Depending on hardware conditions (signals on pins SEL_ED, KEY, OSD2 to OSD0, MP7 to MP0, VP7 to VP0 and DP7 to DP0) and different software programming either data from the MP port, from the VP port, or from the OSD port are selected to be encoded to CVBS and Y/C signals.

Optionally, the OSD colour look-up tables located in this block, can be read out in a pre-defined sequence (8 steps per active video line), achieving e.g. a colour bar test pattern generator without need for an external data source. The colour bar function is only under software control.

Encoder

VIDEO PATH

The encoder generates out of Y, U and V baseband signals luminance and colour subcarrier output signals, suitable for use as CVBS or separate Y/C signals.

Luminance is modified in gain and in offset (latter programmable in a certain range to enable different black level set-ups). After having been inserted a fixed synchronization level, in accordance with standard composite synchronization schemes, a variable blanking level, programmable also in a certain range, is inserted.

In order to enable easy analog post filtering, luminance is interpolated from 13.5 MHz data rate to 27 MHz data rate, providing luminance in 10-bit resolution. This filter is also used to define smoothed transients for synchronization pulses and blanking period. For transfer characteristic of the luminance interpolation filter see Figs 5 and 6.

Digital Video Encoder (DENC2)

SAA7185

Chrominance is modified in gain (programmable separately for U and V), standard dependent burst is inserted, before baseband colour signals are interpolated from 6.75 MHz data rate to 27 MHz data rate. One of the interpolation stages can be bypassed, thus providing a higher colour bandwidth, which can be made use of for Y/C output. For transfer characteristics of the chrominance interpolation filter see Figs 3 and 4.

The amplitude of inserted burst is programmable in a certain range, suitable for standard signals and for special effects. Behind the succeeding quadrature modulator, colour in 10-bit resolution is provided on subcarrier.

The numeric ratio between Y and C outputs is in accordance with set standards.

CLOSED CAPTION ENCODER

Using this circuit, data in accordance with the specification of Closed Caption or Extended Data Service, delivered by the control interface, can be encoded (Line 21). Two dedicated pairs of bytes (two bytes per field), each pair preceded by run-in clocks and framing code, are possible.

The actual line number where data is to be encoded in, can be modified in a certain range.

Data clock frequency is in accordance with definition for NTSC-M standard 32 times horizontal line frequency.

Data LOW at the output of the DACs corresponds to 0 IRE, data HIGH at the output of the DACs corresponds to approximately 50 Ω.

It is also possible to encode Closed Caption Data for 50 Hz field frequencies at 32 times horizontal line frequency.

Output Interface

In the output interface encoded Y and C signals are converted from digital-to-analog in 10-bit resolution both Y and C signals are combined to a 10-bit CVBS signal, also; in front of the summation point, the luminance signal can optionally be fed through a further filter stage, suppressing components in the range of subcarrier frequency. Thus, a type of Cross Colour reduction is provided, which is useful in a standard TV set with CVBS input.

Slopes of synchronization pulses are not affected with any Cross Colour reduction active.

Three different filter characteristics or bypass are available, see Fig.5.

The CVBS output occurs with the same processing delay as the Y and C outputs. Absolute amplitudes at the input of the DAC for CVBS is reduced by $\frac{15}{16}$ with respect to Y and C DACs to make maximum use of conversion ranges.

Outputs of all DACs can be set together via software control to minimum output voltage for either purpose.

Synchronization

The synchronization of the DENC2 is able to operate in two modes; slave mode and master mode.

In the slave mode, the circuit accepts synchronization pulses at the bidirectional RCV1 port. The timing and trigger behaviour related to the video signal on VP (and DP, if used) can be influenced by programming the polarity and on-chip delay of RCV1. Active slope of RCV1 defines the vertical phase and optionally the odd/even and colour frame phase to be initialized, it can be also used to set the horizontal phase.

If the horizontal phase is not be influenced by RCV1, a horizontal pulse needs to be supplied at the RCV2 pin. Timing and trigger behaviour can also be influenced for RCV2.

If there are missing pulses at RCV1 and/or RCV2, the time base of DENC2 runs free, thus an arbitrary number of synchronization slopes may miss, but no additional pulses (such with wrong phase) must occur.

If the vertical and horizontal phase is derived from RCV1, RCV2 can be used for horizontal or composite blanking input or output.

In the master mode, the time base of the circuit continuously runs free. On the RCV1 port, the IC can output:

- A Vertical Sync signal (VS) with 3 or 2.5 lines duration, or
- An ODD/EVEN signal which is LOW in odd fields, or
- A field sequence signal (FSEQ) which is HIGH in the first of 4 respectively 8 fields.

On the RCV2 port, the IC can provide a horizontal pulse with programmable start and stop phase; this pulse can be inhibited in the vertical blanking period to build up e.g. a composite blanking signal.

The phase of the pulses output on RCV1 or RCV2 are referenced to the VP port, polarity of both signals is selectable.

Digital Video Encoder (DENC2)

SAA7185

The DENC2 is **always** the timing master for the source at the MP input. The IC provides two signals for synchronizing this source:

On the RCM1 port the same signals as on RCV1 (as output) are available; on RCM2 the IC provides a horizontal pulse with programmable start and stop phase.

The length of a field also start and end of its active part can be programmed. The active part of a field always starts at the beginning of a line.

Control interface

DENC2 contains two control interfaces: an I²C-bus slave transceiver and 8-bit parallel microprocessor interface. The interfaces cannot be used simultaneously.

The I²C-bus interface is a standard slave transceiver, supporting 7-bit slave addresses and 100 kbits/s guaranteed transfer rate. It uses 8-bit subaddressing with an auto-increment function. All registers are write only, except one readable status byte.

Two I²C-bus slave addresses can be selected (pin SEL_MPU must be LOW):

88H: LOW at pin 61

8CH: HIGH at pin 61.

The parallel interface is defined by:

D7 to D0 data bus

\overline{CS} active-LOW chip select signal

\overline{RW} read/not write signal, LOW for a write cycle

\overline{DTACK} 680xx style data acknowledge (handshake), active-LOW

A0 register select, LOW selects address, HIGH selects data.

The parallel interface uses two registers, one auto-incremental containing the current address of a control register (equals subaddress with I²C-bus control), one containing actual data. The currently addressed register is mapped to the corresponding control register.

The status byte can be read optionally via a read access to the address register, no other read access is provided.

Input levels and formats

DENC2 expects digital YUV data with levels (digital codes) in accordance with CCIR 601.

Deviating amplitudes of the colour difference signals can be compensated by independent gain control setting, while gain for luminance is set to predefined values, distinguishable for 7.5 IRE set-up or without set-up.

The MPEG port accepts only 8-bit multiplexed CCIR 656 compatible data.

If the I²C-bus interface is used, the VP port can handle both formats, 8-bit multiplexed Cb-Y-Cr data on the VP lines, or the 16-bit DTV2 format with the Y signal on the VP lines and the UV signal on the DP port.

Reference levels are measured with a colour bar, 100% white, 100% amplitude and 100% saturation.

Digital Video Encoder (DENC2)

SAA7185

Table 1 CCIR signal component levels

SIGNAL	IRE	DIGITAL LEVEL	CODE
Y	0	16	straight binary
	50	126	
	100	235	
Cb	bottom peak	16	straight binary
	colourless	128	
	top peak	240	
Cr	bottom peak	16	straight binary
	colourless	128	
	top peak	240	

Table 2 8-bit multiplexed format (similar to CCIR 656)

TIME	0	1	2	2	4	5	6	7
Sample	Cb ₀	Y ₀	Cr ₀	Y ₁	Cb ₂	Y ₂	Cr ₂	Y ₃
Luminance pixel number	0		1		2		3	
Colour pixel number	0				2			

Table 3 16-bit multiplexed format (DTV2 format)

TIME	0	1	2	3	4	5	6	7
Sample Y line	Y ₀		Y ₁		Y ₂		Y ₃	
Sample UV line	Cb ₀		Cr ₀		Cb ₂		Cr ₂	
Luminance pixel number	0		1		2		3	
Colour pixel number	0				2			

Digital Video Encoder (DENC2)

SAA7185

Bit allocation map

Table 4 Slave Receiver (Slave Address 88H or 8CH)

REGISTER FUNCTION	SUB ADDRESS	DATA BYTE (note 1)							
		D7	D6	D5	D4	D3	D2	D1	D0
Null	00	0	0	0	0	0	0	0	0
	↓	↓							
Null	39	0	0	0	0	0	0	0	0
Input port control	3A	CBENB	0	0	V656	VY2C	VUV2C	MY2C	MUV2C
OSD LUT Y0	42	OSDY07	OSDY06	OSDY05	OSDY04	OSDY03	OSDY02	OSDY01	OSDY00
OSD LUT U0	43	OSDU07	OSDU06	OSDU05	OSDU04	OSDU03	OSDU02	OSDU01	OSDU00
OSD LUT V0	44	OSDV07	OSDV06	OSDV05	OSDV04	OSDV03	OSDV02	OSDV01	OSDV00
	↓	↓							
OSD LUT Y7	57	OSDY77	OSDY76	OSDY75	OSDY74	OSDY73	OSDY72	OSDY71	OSDY70
OSD LUT U7	58	OSDU77	OSDU76	OSDU75	OSDU74	OSDU73	OSDU72	OSDU71	OSDU70
OSD LUT V7	59	OSDV77	OSDV76	OSDV75	OSDV74	OSDV73	OSDV72	OSDV71	OSDV70
Chrominance phase	5A	CHPS7	CHPS6	CHPS5	CHPS4	CHPS3	CHPS2	CHPS1	CHPS0
Gain U	5B	GAINU7	GAINU6	GAINU5	GAINU4	GAINU3	GAINU2	GAINU1	GAINU0
Gain V	5C	GAINV7	GAINV6	GAINV5	GAINV4	GAINV3	GAINV2	GAINV1	GAINV0
Gain U MSB, black level	5D	GAINU8	0	BLCKL5	BLCKL4	BLCKL3	BLCKL2	BLCKL1	BLCKL0
Gain V MSB, blanking level	5E	GAINV8	0	BLNNL5	BLNNL4	BLNNL3	BLNNL2	BLNNL1	BLNNL0
Null	5F	0	0	0	0	0	0	0	0
Cross-colour select	60	CCRS1	CCRS0	0	0	0	0	0	0
Standard control	61	0	DOWN	INPI1	YGS	RTCE	SCBW	PAL	FISE
Burst amplitude	62	SQP	BSTA6	BSTA5	BSTA4	BSTA3	BSTA2	BSTA1	BSTA0
Subcarrier 0	63	FSC07	FSC06	FSC05	FSC04	FSC03	FSC02	FSC01	FSC00
Subcarrier 1	64	FSC15	FSC14	FSC13	FSC12	FSC11	FSC10	FSC09	FSC08
Subcarrier 2	65	FSC23	FSC22	FSC21	FSC20	FSC19	FSC18	FSC17	FSC16
Subcarrier 3	66	FSC31	FSC30	FSC29	FSC28	FSC27	FSC26	FSC25	FSC24
Line 21 odd 0	67	L21O07	L21O06	L21O05	L21O04	L21O03	L21O02	L21O01	L21O00
Line 21 odd 1	68	L21O17	L21O16	L21O15	L21O14	L21O13	L21O12	L21O11	L21O10
Line 21 even 0	69	L21E07	L21E06	L21E05	L21E04	L21E03	L21E02	L21E01	L21E00
Line 21 even 1	6A	L21E17	L21E16	L21E15	L21E14	L21E13	L21E12	L21E11	L21E10
Encoder control, CC line	6B	MODIN1	MODIN0	0	SCCLN4	SCCLN3	SCCLN2	SCCLN1	SCCLN0

Digital Video Encoder (DENC2)

SAA7185

REGISTER FUNCTION	SUB ADDRESS	DATA BYTE (note 1)							
		D7	D6	D5	D4	D3	D2	D1	D0
RCV port control	6C	SRCV11	SRCV10	TRCV2	ORCV1	PRCV1	CBLF	ORCV2	PRCV2
RCM, CC mode	6D	0	0	0	0	SRCM11	SRCM10	CCEN1	CCEN0
Horizontal trigger	6E	HTRIG7	HTRIG6	HTRIG5	HTRIG4	HTRIG3	HTRIG2	HTRIG1	HTRIG0
Horizontal trigger	6F	0	0	0	0	0	HTRIG10	HTRIG09	HTRIG08
f _{sc} reset mode, Vertical trigger	70	PHRES1	PHRES0	SBLBN	VTRIG4	VTRIG3	VTRIG2	VTRIG1	VTRIG0
Begin MP request	71	BMRQ7	BMRQ6	BMRQ5	BMRQ4	BMRQ3	BMRQ2	BMRQ1	BMRQ0
End MP request	72	EMRQ7	EMRQ6	EMRQ5	EMRQ4	EMRQ3	EMRQ2	EMRQ1	EMRQ0
MSBs MP request	73	0	EMRQ10	EMRQ09	EMRQ08	0	BMRQ10	BMRQ09	BMRQ08
Null	74	0	0	0	0	0	0	0	0
Null	75	0	0	0	0	0	0	0	0
Null	76	0	0	0	0	0	0	0	0
Begin RCV2 output	77	BRCV7	BRCV6	BRCV5	BRCV4	BRCV3	BRCV2	BRCV1	BRCV0
End RCV2 output	78	ERCV7	ERCV6	ERCV5	ERCV4	ERCV3	ERCV2	ERCV1	ERCV0
MSBs RCV2 output	79	0	ERCV10	ERCV09	ERCV08	0	BRCV10	BRCV09	BRCV08
Field length	7A	FLEN7	FLEN6	FLEN5	FLEN4	FLEN3	FLEN2	FLEN1	FLEN0
First active line	7B	FAL7	FAL6	FAL5	FAL4	FAL3	FAL2	FAL1	FAL0
Last active line	7C	LAL7	LAL6	LAL5	LAL4	LAL3	LAL2	LAL1	LAL0
MSBs field control	7D	0	0	LAL8	FAL8	0	0	FLEN9	FLEN8

Note

- All bits labelled '0' are reserved. They **must** be programmed with logic 0.

Digital Video Encoder (DENC2)

SAA7185

I²C-bus format

Table 5 I²C-bus address; see Table 6

S	SLAVE ADDRESS	ACK	SUBADDRESS	ACK	DATA 0	ACK	-----	DATA n	ACK	P
---	---------------	-----	------------	-----	--------	-----	-------	--------	-----	---

Table 6 Explanation of Table 5

PART	DESCRIPTION
S	START condition
Slave address	1 0 0 0 1 0 0 X or 1 0 0 0 1 1 0 X (note 1)
ACK	acknowledge, generated by the slave
Subaddress (note 2)	subaddress byte
DATA	data byte
-----	continued data bytes and ACKs
P	STOP condition

Notes

1. X is the read/write control bit; X = logic 0 is order to write; X = logic 1 is order to read, no subaddressing with read.
2. If more than 1 byte DATA is transmitted, then auto-increment of the subaddress is performed.

Slave Receiver

Table 7 Subaddress 3A

DATA BYTE	LOGIC LEVEL	DESCRIPTION
MUV2C	0	Cb/Cr data at MP are two's complement.
	1	Cb/Cr data at MP are straight binary. Default after reset.
MY2C	0	Y data at MP are two's complement.
	1	Y data at MP are straight binary. Default after reset.
VUV2C	0	Cb/Cr data input to VP or DP are two's complement. Default after reset.
	1	Cb/Cr data input to VP or DP are straight binary.
VY2C	0	Y data input to VP are two's complement. Default after reset.
	1	Y data input to VP are straight binary.
V656	0	Selects YUV 422 format on VP (8 lines Y) and DP (8 lines multiplexed Cb/Cr).
	1	Selects CCIR 656 compatible format on VP (8 lines Cb, Y, Cr). Default after reset.
CBENB	0	Data from input ports are encoded. Default after reset.
	1	Colour bar with programmable colours (entries of OSD_LUTs) is encoded. The LUTs are read in upward order from index 0 to index 7.

Digital Video Encoder (DENC2)

SAA7185

Table 8 Subaddress 42 to 59

COLOUR	DATA BYTE (note 1)			INDEX (note 2)
	OSDY	OSDU	OSDV	
White	107 (6BH)	0 (00H)	0 (00H)	0
	107 (6BH)	0 (00H)	0 (00H)	
Yellow	82 (52H)	144 (90H)	18 (12H)	1
	34 (22H)	172 (ACH)	14 (0Eh)	
Cyan	42 (2AH)	38 (26H)	144 (90H)	2
	03 (03H)	29 (1DH)	172 (ACH)	
Green	17 (11H)	182 (B6H)	162 (A2H)	3
	240 (F0H)	200 (C8H)	185 (B9H)	
Magenta	234 (EAH)	74 (4AH)	94 (5EH)	4
	212 (D4H)	56 (38H)	71 (47H)	
Red	209 (D1H)	218 (DAH)	112 (70H)	5
	193 (C1H)	227 (E3H)	84 (54H)	
Blue	169 (A9H)	112 (70H)	238 (EEH)	6
	163 (A3H)	84 (54H)	242 (F2H)	
Black	144 (90H)	0 (00H)	0 (00H)	7
	144 (90H)	0 (00H)	0 (00H)	

Notes

- Contents of OSD Look-up tables. All 8 entries are 8-bits. Data representation is in accordance with CCIR 601 (Y, Cb, Cr), but two's complement, e.g. for a $^{100}_{100}$ (upper number) or $^{100}_{75}$ (lower number) colour bar.
- For normal colour bar with CBENB = logic 1.

Table 9 Subaddress 5A

DATA BYTE	DESCRIPTION
CHPS	Phase of encoded colour subcarrier (including burst) relative to horizontal sync. Can be adjusted in steps of 360/256 degrees.

Table 10 Subaddress 5B and 5D

DATA BYTE	DESCRIPTION	CONDITIONS	REMARKS
GAINU	variable gain for Cb signal; input representation accordance with CCIR 601	white-to-black = 92.5 IRE ⁽¹⁾ GAINU = 0 GAINU = 118 (76H)	output subcarrier of U contribution = 0 output subcarrier of U contribution = nominal
		white-to-black = 100 IRE ⁽²⁾ GAINU = 0 GAINU = 125 (7DH)	output subcarrier of U contribution = 0 output subcarrier of U contribution = nominal

Notes

- GAINU = $-2.17 \times \text{nominal}$ to $+2.16 \times \text{nominal}$.
- GAINU = $-2.05 \times \text{nominal}$ to $+2.04 \times \text{nominal}$.

Digital Video Encoder (DENC2)

SAA7185

Table 11 Subaddress 5C and 5E

DATA BYTE	DESCRIPTION	CONDITIONS	REMARKS
GAINV	variable gain for Cr signal; input representation accordance with CCIR 601	white-to-black = 92.5 IRE ⁽¹⁾ GAINV = 0 GAINV = 165 (A5H)	output subcarrier of V contribution = 0 output subcarrier of V contribution = nominal
		white-to-black = 100 IRE ⁽²⁾ GAINV = 0 GAINV = 175 (AFH)	output subcarrier of V contribution = 0 output subcarrier of V contribution = nominal

Notes

1. GAINV = $-1.55 \times \text{nominal}$ to $+1.55 \times \text{nominal}$.
2. GAINV = $-1.46 \times \text{nominal}$ to $+1.46 \times \text{nominal}$.

Table 12 Subaddress 5D

DATA BYTE	DESCRIPTION	CONDITIONS	REMARKS
BLCKL	variable black level; input representation accordance with CCIR 601	white-to-sync = 140 IRE ⁽¹⁾ BLCKL = 0 BLCKL = 63 (3FH)	output black level = 24 IRE output black level = 49 IRE
		white-to-sync = 143 IRE ⁽²⁾ BLCKL = 0 BLCKL = 63 (3FH)	output black level = 24 IRE output black level = 50 IRE

Notes

1. Output black level/IRE = $\text{BLCKL} \times 25/63 + 24$; recommended value: BLCKL = 60 (3CH) normal.
2. Output black level/IRE = $\text{BLCKL} \times 26/63 + 24$; recommended value: BLCKL = 45 (2DH) normal.

Table 13 Subaddress 5E

DATA BYTE	DESCRIPTION	CONDITIONS	REMARKS
BLNNL	variable blanking level	white-to-sync = 140 IRE ⁽¹⁾ BLNNL = 0 BLNNL = 63 (3FH)	output blanking level = 17 IRE output blanking level = 42 IRE
		white-to-sync = 143 IRE ⁽²⁾ BLNNL = 0 BLNNL = 63 (3FH)	output blanking level = 17 IRE output blanking level = 43 IRE

Notes

1. Output black level/IRE = $\text{BLNNL} \times 25/63 + 17$; recommended value: BLNNL = 58 (3AH) normal.
2. Output black level/IRE = $\text{BLNNL} \times 26/63 + 17$; recommended value: BLNNL = 63 (3FH) normal.

Digital Video Encoder (DENC2)

SAA7185

Table 14 Subaddress 60 (CCRS; select cross colour reduction filter in luminance)

DATA BYTE		FUNCTION
CCRS1	CCRS0	
0	0	no cross colour reduction (for overall transfer characteristic of luminance see Fig.5)
0	1	cross colour reduction #1 active (for overall transfer characteristic see Fig.5)
1	0	cross colour reduction #2 active (for overall transfer characteristic see Fig.5)
1	1	cross colour reduction #3 active (for overall transfer characteristic see Fig.5)

Table 15 Subaddress 61

DATA BYTE	LOGIC LEVEL	DESCRIPTION
FISE	0	864 total pixel clocks per line
	1	858 total pixel clocks per line; default after reset
PAL	0	NTSC encoding (non-alternating V component); default after reset
	1	PAL encoding (alternating V component)
SCBW	0	enlarged bandwidth for chrominance encoding (for overall transfer characteristic of chrominance in baseband representation see Figs 3 and 4)
	1	standard bandwidth for chrominance encoding (for overall transfer characteristic of chrominance in baseband representation see Figs 3 and 4); default after reset
RTCE	0	no real time control of generated subcarrier frequency; default after reset
	1	real time control of generated subcarrier frequency through SAA7151B (timing see Fig.9)
YGS	0	luminance gain for white – black 100 IRE
	1	luminance gain for white – black 92.5 IRE including 7.5 IRE set-up of black; default after reset
INPI	0	PAL switch phase is nominal; default after reset
	1	PAL switch phase is inverted compared to nominal
DOWN	0	DACs in normal operational mode (not defined after reset, program after all zero-bits are set to zero)
	1	DACs forced to lowest output voltage (not defined after reset, program after all zero-bits are set to zero)

Digital Video Encoder (DENC2)

SAA7185

Table 16 Subaddress 62

DATA BYTE	DESCRIPTION	CONDITIONS	REMARKS
BSTA	amplitude of colour burst; input representation accordance with CCIR 601	white-to-black = 92.5 IRE; burst = 40 IRE; NTSC encoding BSTA = 0 to $1.25 \times \text{nominal}^{(1)}$ white-to-black = 92.5 IRE; burst = 40 IRE; PAL encoding BSTA = 0 to $1.76 \times \text{nominal}^{(2)}$ white-to-black = 100 IRE; burst = 43 IRE; NTSC encoding BSTA = 0 to $1.20 \times \text{nominal}^{(3)}$ white-to-black = 100 IRE; burst = 43 IRE; PAL encoding BSTA = 0 to $1.67 \times \text{nominal}^{(4)}$	
SQP	subcarrier real time	logic 0	control from SAA7151B digital colour decoder
		logic 1	not supported in current version, do not use

Notes

1. Recommended value: BSTA = 102 (66H).
2. Recommended value: BSTA = 72 (48H).
3. Recommended value: BSTA = 106 (6AH).
4. Recommended value: BSTA = 75 (4BH).

Table 17 Subaddress 63 to 66 (four bytes to program subcarrier frequency)

DATA BYTE	DESCRIPTION	CONDITIONS	REMARKS
FSC0 to FSC3	f_{fsc} = subcarrier frequency (in multiples of line frequency); f_{llc} = clock frequency (in multiples of line frequency)	$\text{FSC} = \text{round}\left(\frac{f_{\text{fsc}}}{f_{\text{llc}}} \times 2^{32}\right)$ see note 1	FSC3 = most significant byte FSC0 = least significant byte

Notes

1. Examples:
 - a) NTSC-M: $f_{\text{fsc}} = 227.5 \text{ MHz}$, $f_{\text{llc}} = 1716 \text{ MHz}$ → FSC = 569408543 (21F07C1FH).
 - b) PAL-B/G: $f_{\text{fsc}} = 283.7516 \text{ MHz}$, $f_{\text{llc}} = 1728 \text{ MHz}$ → FSC = 705268427 (2A098ACBH).

Digital Video Encoder (DENC2)

SAA7185

Table 18 Subaddress 67 to 6A

DATA BYTE ⁽¹⁾	DESCRIPTION
L21O0	first byte of captioning data, odd field
L21O1	second byte of captioning data, odd field
L21E0	first byte of extended data, even field
L21E1	second byte of extended data, even field

Note

1. LSBs of the respective bytes are encoded immediately after run-in and framing code, the MSBs of the respective bytes have to carry the parity bit, in accordance with the definition of line 21 encoding format.

Table 19 Subaddress 6B

DATA BYTE	DESCRIPTION
SCCLN	selects the actual line, where closed caption or extended data are encoded; see note 1
MODIN	defines video data of MP port or VP(DP) port to be encoded; see Table 20

Note

1. Line = (SCCLN + 4) for M systems; line = (SCCLN + 1) for other systems.

Table 20 Logic levels and function of MODIN

DATA BYTE		FUNCTION
MODIN1	MODIN0	
0	0	unconditionally from MP port
0	1	from MP port, if pin SEL_ED = HIGH; otherwise from VP port
1	0	unconditionally from VP port
1	1	from VP port, if pin SEL_ED = HIGH; otherwise from MP port

Digital Video Encoder (DENC2)

SAA7185

Table 21 Subaddress 6C

DATA BYTE	LOGIC LEVEL	DESCRIPTION
PRCV2	0	polarity of RCV2 as output is active HIGH, rising edge is taken when input, respectively; default after reset
	1	polarity of RCV2 as output is active LOW, falling edge is taken when input, respectively
ORCV2	0	pin RCV2 is switched to input; default after reset
	1	pin RCV2 is switched to output
CBLF	0	if ORCV2 = HIGH, pin RCV2 provides an HREF signal (Horizontal Reference Pulse that is HIGH during active portion of line, also during vertical blanking Interval); default after reset
	1	if ORCV2 = LOW, signal input to RCV2 is used for horizontal synchronization only (if TRCV2 = 1); default after reset if ORCV2 = LOW, signal input to RCV2 is used for horizontal synchronization (if TRCV2 = 1) also as an internal blanking signal
PRCV1	0	polarity of RCV1 as output is active HIGH, rising edge is taken when input, respectively; default after reset
	1	polarity of RCV1 as output is active LOW, falling edge is taken when input, respectively
ORCV1	0	pin RCV1 is switched to input; default after reset
	1	pin RCV1 is switched to output
TRCV2	0	horizontal synchronization is taken from RCV1 port; default after reset
	1	horizontal synchronization is taken from RCV2 port
SRCV1	–	defines signal type on pin RCV1; see Table 22

Table 22 Logic levels and function of SRCV1

DATA BYTE		AS OUTPUT	AS INPUT	FUNCTION
SRCV11	SRCV10			
0	0	VS	VS	Vertical Sync each field; default after reset
0	1	FS	FS	Frame Sync (odd/even)
1	0	FSEQ	FSEQ	Field Sequence, vertical sync every fourth field (FISE = 1) or eighth field (FISE = 0)
1	1	–	–	not applicable

Table 23 Subaddress 6D

DATA BYTE	DESCRIPTION
CCEN	enables individual line 21 encoding; see Table 24
SRCM	defines signal type on pin RCM1; see Table 25

Digital Video Encoder (DENC2)

SAA7185

Table 24 Logic levels and function of CCEN

DATA BYTE		FUNCTION
CCEN1	CCEN0	
0	0	line 21 encoding OFF
0	1	enables encoding in field 1 (odd)
1	0	enables encoding in field 2 (even)
1	1	enables encoding in both fields

Table 25 Logic levels and function of SRCM

DATA BYTE		AS OUTPUT	FUNCTION
SRCM1	SRCM0		
0	0	VS	Vertical Sync each field
0	1	FS	Frame Sync (odd/even)
1	0	FSEQ	Field Sequence, vertical sync every fourth field (FISE = 1) or eighth field (FISE = 0)
1	1	–	not applicable

Table 26 Subaddress 6E to 6F

DATA BYTE	DESCRIPTION
HTRIG	sets the Horizontal Trigger phase related to signal on RCV1 or RCV2 input values above 1715 (FISE = 1) or 1727 (FISE = 0) are not allowed increasing HTRIG decreases delays of all internally generated timing signals reference mark: analog output horizontal sync (leading slope) coincides with active edge of RCV used for triggering at HTRIG = 032H

Table 27 Subaddress 70

DATA BYTE	LOGIC LEVEL	DESCRIPTION
VTRIG	–	sets the Vertical TRIGger phase related to signal on RCV1 input increasing VTRIG decreases delays of all internally generated timing signals, measured in half lines variation range of VTRIG = 0 to 31 (1FH)
SBLBN	0	vertical blanking is defined by programming of FAL and LAL
	1	vertical blanking is forced automatically at least during field synchronization and equalization pulses; note 1
PHRES	–	selects the phase reset mode of the colour subcarrier generator; see Table 28

Note

1. If cross-colour reduction is programmed, it is active between FAL and LAL in both events.

Digital Video Encoder (DENC2)

SAA7185

Table 28 Logic levels and function of PHRES

DATA BYTE		FUNCTION
PHRES1	PHRES0	
0	0	no reset
0	1	reset every two lines
1	0	reset every eight fields
1	1	reset every four fields

Table 29 Subaddress 71 to 73

DATA BYTE	DESCRIPTION
BMRQ	beginning of MP ReQuest signal (RCM2) values above 1715 (FISE = 1) or 1727 (FISE = 0) are not allowed first active pixel at analog outputs (corresponding input pixel coinciding with RCM2) at BMRQ = 0F9H (115H)
EMRQ	end of MP ReQuest signal (RCM2) values above 1715 (FISE = 1) or 1727 (FISE = 0) are not allowed last active pixel at analog outputs (corresponding input pixel coinciding with RCM2) at EMRQ = 686H (690H)

Table 30 Subaddress 77 to 79

DATA BYTE	DESCRIPTION
BRCV	beginning of output signal on RCV2 pin values above 1715 (FISE = 1) or 1727 (FISE = 0) are not allowed first active pixel at analog outputs (corresponding input pixel coinciding with RCV2) at BRCV = 0F9H (115H)
ERCV	end of output signal on RCV2 pin values above 1715 (FISE = 1) or 1727 (FISE = 0) are not allowed last active pixel at analog outputs (corresponding input pixel coinciding with RCV2) at ERCV = 686H (690H)

Table 31 Subaddress 7A to 7D

DATA BYTE	DESCRIPTION
FLEN	Length of a Field = FLEN + 1, measured in half lines valid range is limited to 524 to 1022 (FISE = 1) respectively 624 to 1022 (FISE = 0), FLEN should be even
FAL	First Active Line after vertical blanking interval = FAL + 1, measured in lines FAL = 0 coincides with the first field synchronization pulse
LAL	Last Active Line before vertical blanking interval = LAL + 1, measured in lines LAL = 0 coincides with the first field synchronization pulse

SUBADDRESSES

In subaddresses 5B, 5C, 5D, 5E and 62 all IRE values are rounded up.

Digital Video Encoder (DENC2)

SAA7185

Slave Transmitter

Table 32 Slave Transmitter (slave address 89H or 8DH)

REGISTER FUNCTION	SUBADDRESS	DATA BYTE							
		D7	D6	D5	D4	D3	D2	D1	D0
Status byte	–	VER2	VER1	VER0	CCRDE	CCRDO	FSQ2	FSQ1	FSQ0

Table 33 No subaddress

DATA BYTE	DESCRIPTION
VER	Version identification of the device. It will be changed with all versions of the IC that have different programming models. Current Version is 000 binary.
CCRDE	Closed caption bytes of the even field have been encoded. The bit is reset after information has been written to the subaddresses 69 and 6A. It is set immediately after the data have been encoded.
CCRDO	Closed caption bytes of the odd field have been encoded. The bit is reset after information has been written to the subaddresses 67 and 68. It is set immediately after the data have been encoded.
FSQ	State of the internal field sequence counter. Bit 0 (FSQ0) gives the odd/even information; odd = LOW, even = HIGH.

Digital Video Encoder (DENC2)

SAA7185

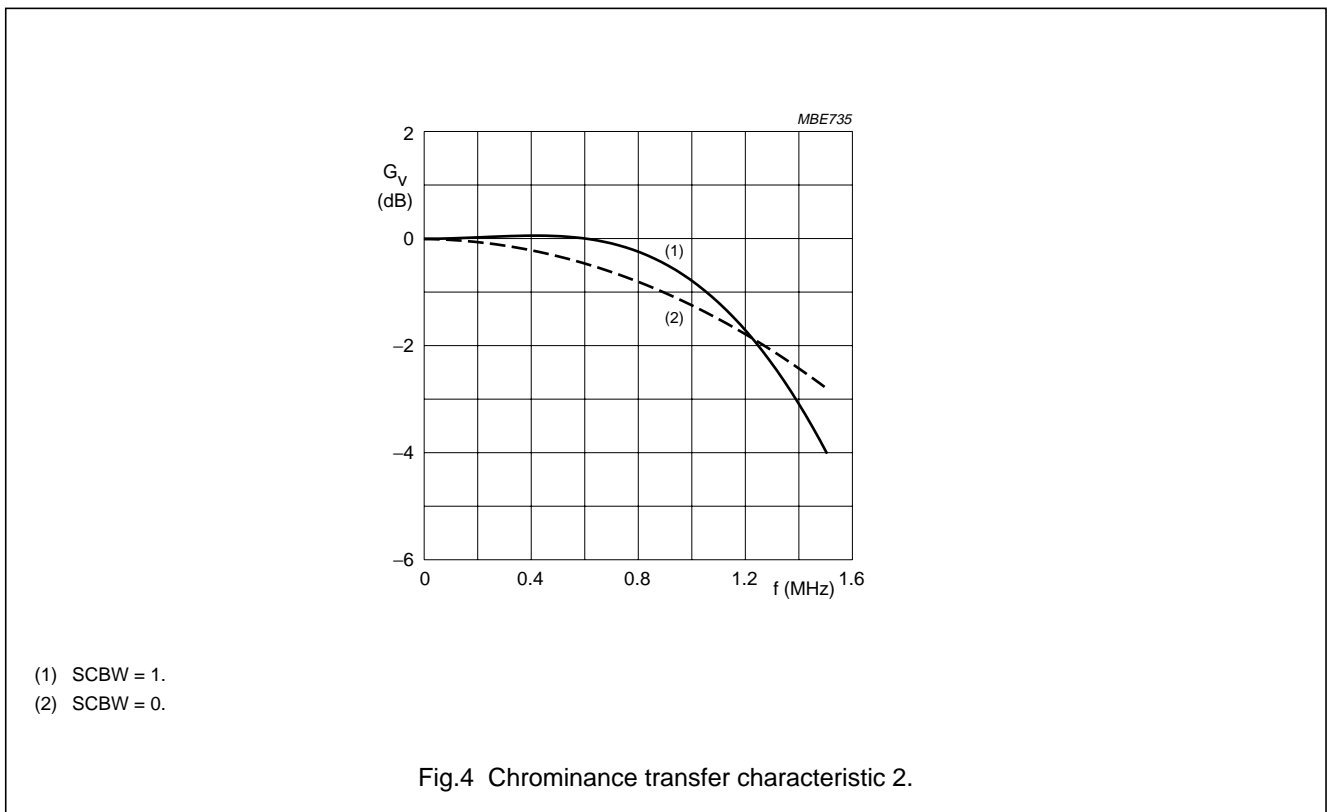
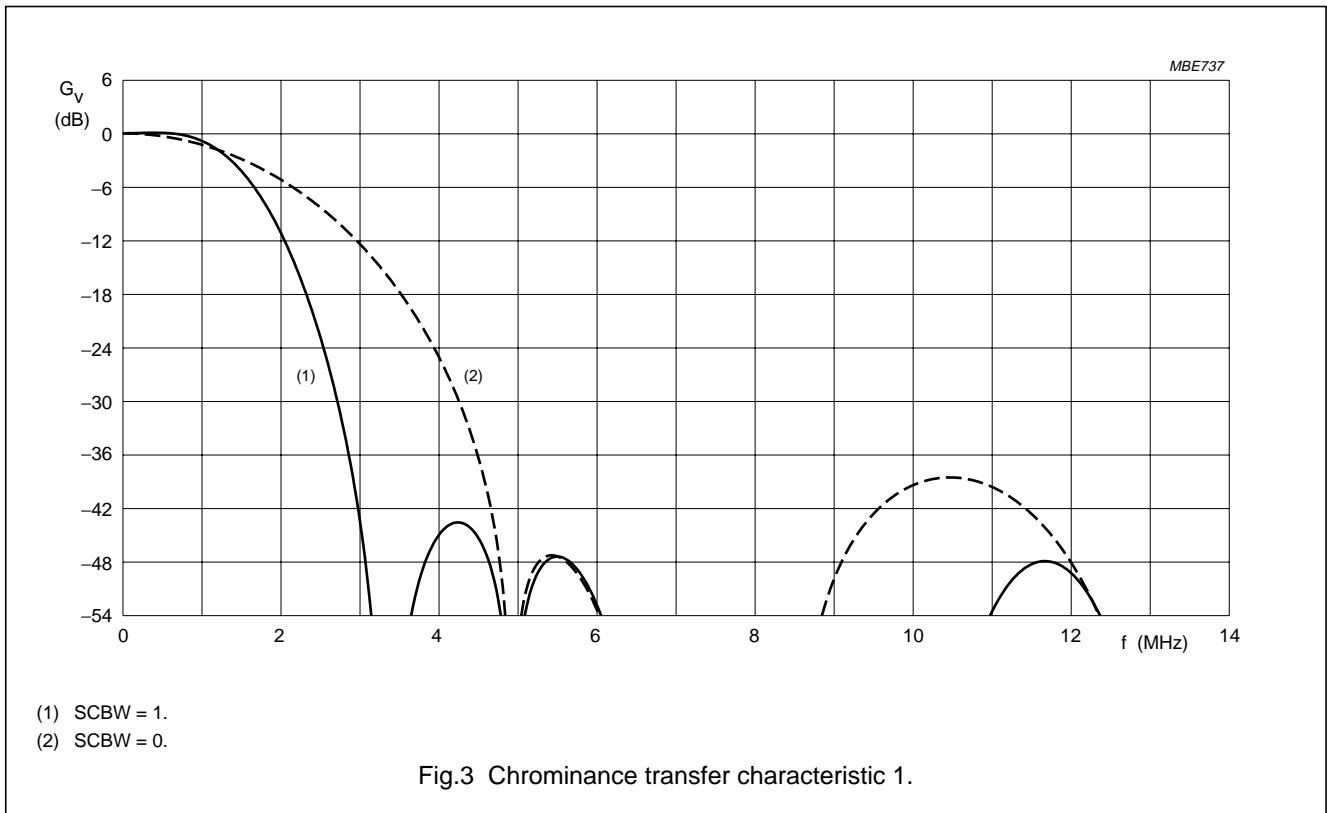

Digital Video Encoder (DENC2)

SAA7185

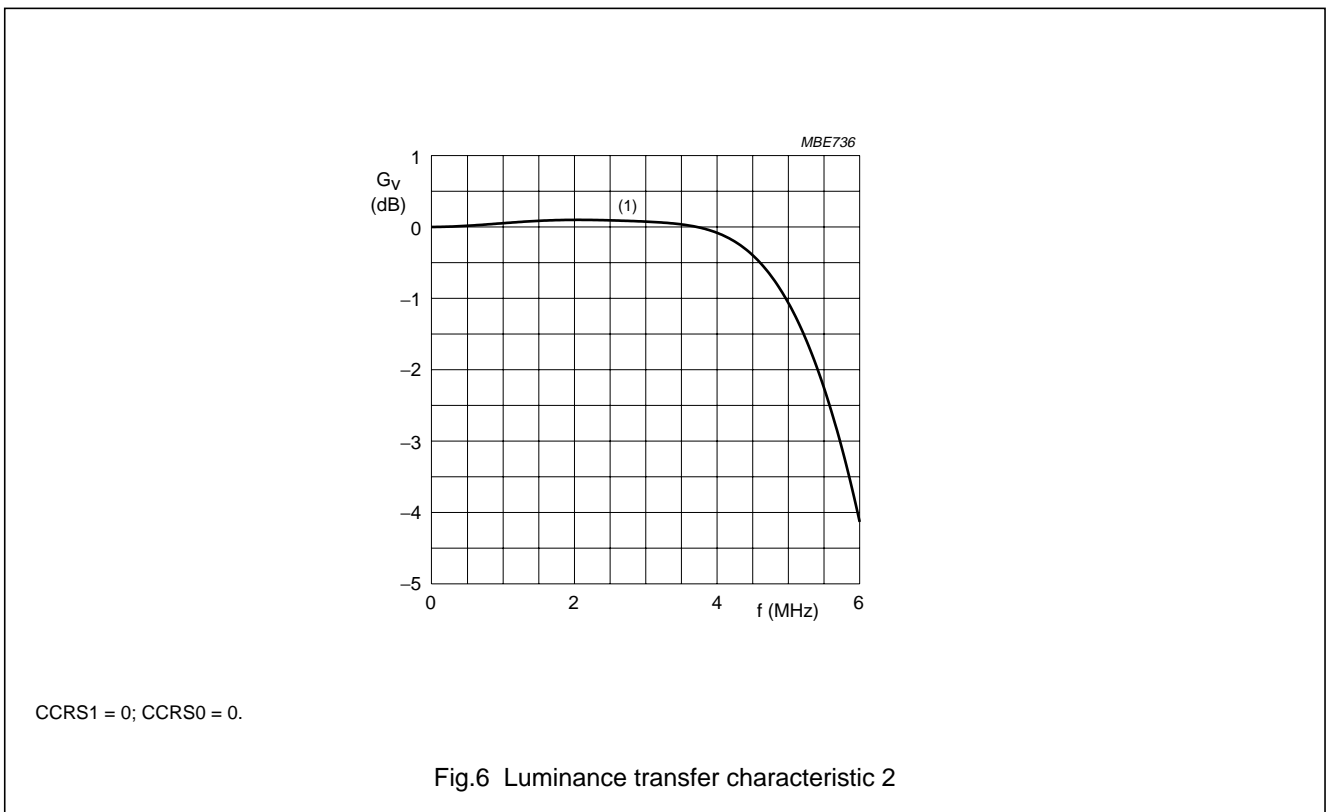
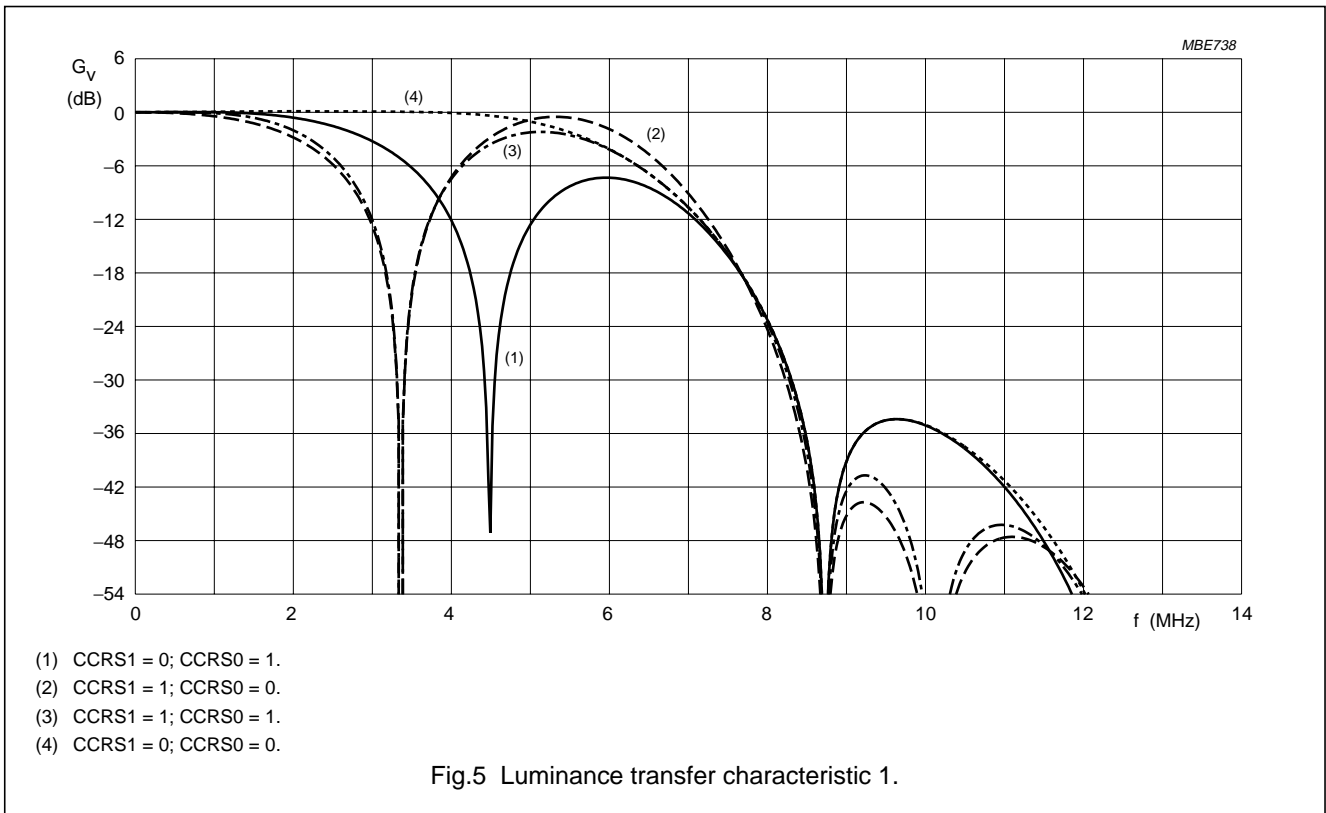

Digital Video Encoder (DENC2)

SAA7185

CHARACTERISTICS $V_{DD} = 4.5$ to 5.5 V; $T_{amb} = 0$ to 70 °C; unless otherwise specified.

SYMBOL	PARAMETER	CONDITIONS	MIN.	MAX.	UNIT
Supply					
V_{DDD}	digital supply voltage		4.5	5.5	V
V_{DDA}	analog supply voltage		4.75	5.25	V
I_{DDD}	digital supply current	note 1	–	170	mA
I_{DDA}	analog supply current	note 1	–	55	mA
Inputs					
V_{IL}	LOW level input voltage (except LLC, SDA, SCL, AP, SP and XTALI)		–0.5	+0.8	V
V_{IH}	HIGH level input voltage (except LLC, SDA, SCL, AP, SP and XTALI)		2.0	$V_{DDD} + 0.5$	V
	HIGH level input voltage (LLC)		2.4	$V_{DDD} + 0.5$	V
V_{LI}	input leakage current		–	1	μ A
C_I	input capacitance	clocks operating	–	10	pF
		data available	–	8	pF
		I/Os at high impedance	–	8	pF
Outputs					
V_{OL}	LOW level output voltage (except SDA and XTALO)	note 2	0	0.6	V
V_{OH}	HIGH level output voltage (except LLC, SDA, \overline{DTACK} and XTALO)	note 2	2.4	$V_{DDD} + 0.5$	V
	HIGH level output voltage (LLC)	note 2	2.6	$V_{DDD} + 0.5$	V
I²C-bus; SDA and SCL					
V_{IL}	LOW level input voltage		–0.5	+1.5	V
V_{IH}	HIGH level input voltage		3.0	$V_{DDD} + 0.5$	V
I_I	input current	$V_I = \text{LOW or HIGH}$	–10	+10	μ A
V_{OL}	LOW level output voltage (SDA)	$I_{OL} = 3$ mA	–	0.4	V
I_O	output current	during acknowledge	3	–	mA
Clock timing (LLC)					
T_{LLC}	cycle time	note 3	34	41	ns
δ	duty factor t_{HIGH}/T_{LLC}	note 4	40	60	%
t_r	rise time	note 3	–	5	ns
t_f	fall time	note 3	–	6	ns

Digital Video Encoder (DENC2)

SAA7185

SYMBOL	PARAMETER	CONDITIONS	MIN.	MAX.	UNIT
Input timing					
$t_{SU;CREF}$	input data set-up time (C_{ref})		6	–	ns
$t_{HD;CREF}$	input data hold time (C_{ref})		3	–	ns
t_{SU}	input data set-up time (any other except SEL_MPU, CDIR, $\overline{RW/SCL}$, A0/SDA, $\overline{CS/SA}$, \overline{RESET} , AP and SP)		6	–	ns
t_{HD}	input data hold time (any other except SEL_MPU, CDIR, $\overline{RW/SCL}$, A0/SDA, $\overline{CS/SA}$, \overline{RESET} , AP and SP)		3	–	ns
Crystal oscillator					
f_n	nominal frequency (usually 27 MHz)	3rd harmonic	–	30	MHz
$\Delta f/f_n$	permissible deviation of nominal frequency	note 5	–50	+50	10^{-6}
CRYSTAL SPECIFICATION					
T_{amb}	operating ambient temperature		0	70	°C
C_L	load capacitance		8	–	pF
R_S	series resistance		–	80	Ω
C_1	motional capacitance (typical)		1.5 –20%	1.5 +20%	fF
C_0	parallel capacitance (typical)		3.5 –20%	3.5 +20%	pF
MPU interface timing					
t_{AS}	address set-up time	note 6	9	–	ns
t_{AH}	address hold time		0	–	ns
$t_{R\overline{WS}}$	read/write set-up time	note 6	9	–	ns
$t_{R\overline{WH}}$	read/write hold time		0	–	ns
t_{DD}	data bus floating from \overline{CS} (read)	notes 7, 8 and 9; n = 9	–	400	ns
t_{DF}	data valid from \overline{CS} (read)	notes 7 and 8; n = 5	–	255	ns
t_{DS}	data bus set-up time (write)	note 6	9	–	ns
t_{DH}	data bus hold time (write)	note 6	9	–	ns
t_{ACS}	acknowledge delay from \overline{CS}	notes 7 and 8; n = 11	–	475	ns
$t_{\overline{CS}D}$	\overline{CS} HIGH from acknowledge		0	–	ns
t_{DAT}	\overline{DTACK} floating from \overline{CS} HIGH	notes 7 and 8; n = 7	–	330	ns
Data and reference signal output timing					
C_L	output load capacitance		7.5	40	pF
t_{OH}	output hold time		4	–	ns
t_{OD}	output delay time	C_{ref} in output mode	–	25	ns

Digital Video Encoder (DENC2)

SAA7185

SYMBOL	PARAMETER	CONDITIONS	MIN.	MAX.	UNIT
CHROMA, Y and CVBS outputs					
$V_{o(p-p)}$	output signal voltage (peak-to-peak value)	note 10	1.9	2.1	V
R_I	internal serial resistance		18	35	Ω
R_L	output load resistance		80	–	Ω
B	output signal bandwidth of DACs	–3 dB	10	–	MHz
ILE	LF integral linearity error of DACs		–	± 2	LSB
DLE	LF differential linearity error of DACs		–	± 1	LSB

Notes

1. At maximum supply voltage with highly active input signals.
2. The levels have to be measured with load circuits of 1.2 k Ω to 3.0 V (standard TTL load) and $C_L = 25$ pF.
3. The data is for both input and output direction.
4. With LLC in input mode. In output mode, with a crystal connected to XTALO/XTALI duty factor is typically 50%.
5. If an internal oscillator is used, crystal deviation of nominal frequency is directly proportional to the deviation of subcarrier frequency and line/field frequency.
6. The value is calculated via equation $t = t_{SU} + t_{HD}$
7. The value depends on the clock frequency. The numbers given are calculated with $f_{LLC} = 27$ MHz.
8. The values given are calculated via equation $t_{dmax} = t_{OD} + n \times t_{LLC} + t_{LLC} + t_{SU}$
9. The falling edge of \overline{DTACK} will always occur $1 \times LLC$ after data is valid.
10. For full digital range, without load, $V_{DDA} = 5.0$ V. The typical voltage swing is 2.0 V, the typical minimum output voltage (digital zero at DAC) is 0.2 V.

Digital Video Encoder (DENC2)

SAA7185

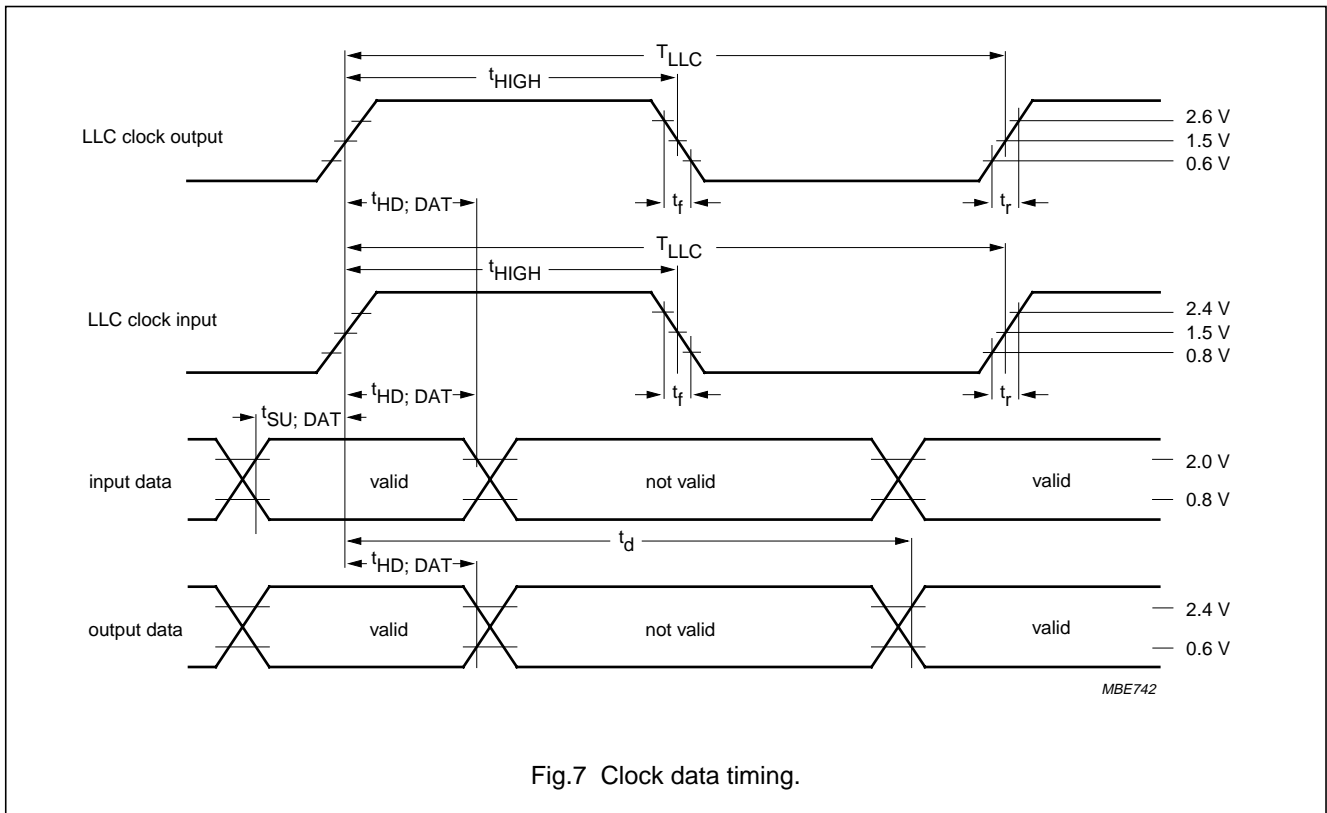
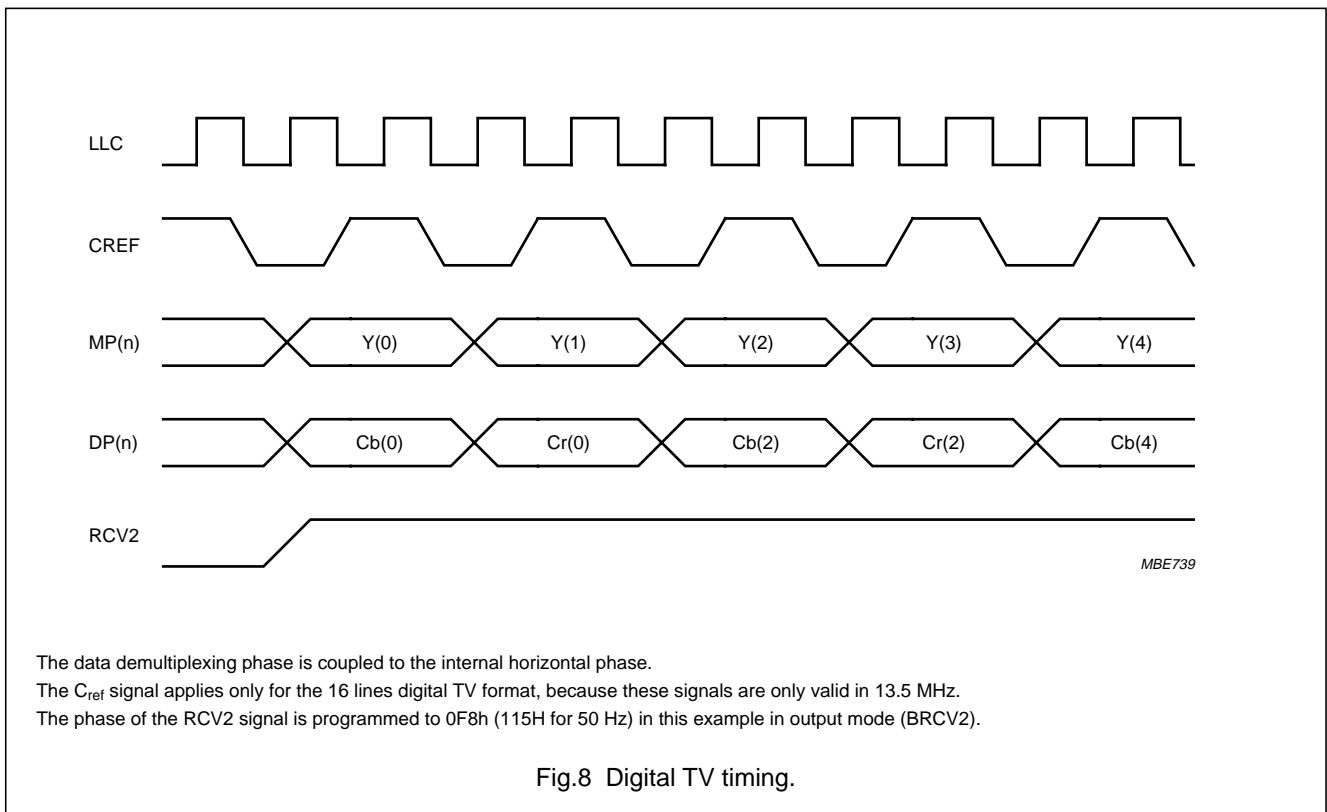

Fig.7 Clock data timing.



The data demultiplexing phase is coupled to the internal horizontal phase.
 The C_{ref} signal applies only for the 16 lines digital TV format, because these signals are only valid in 13.5 MHz.
 The phase of the RCV2 signal is programmed to 0F8h (115H for 50 Hz) in this example in output mode (BRCV2).

Fig.8 Digital TV timing.

Digital Video Encoder (DENC2)

SAA7185

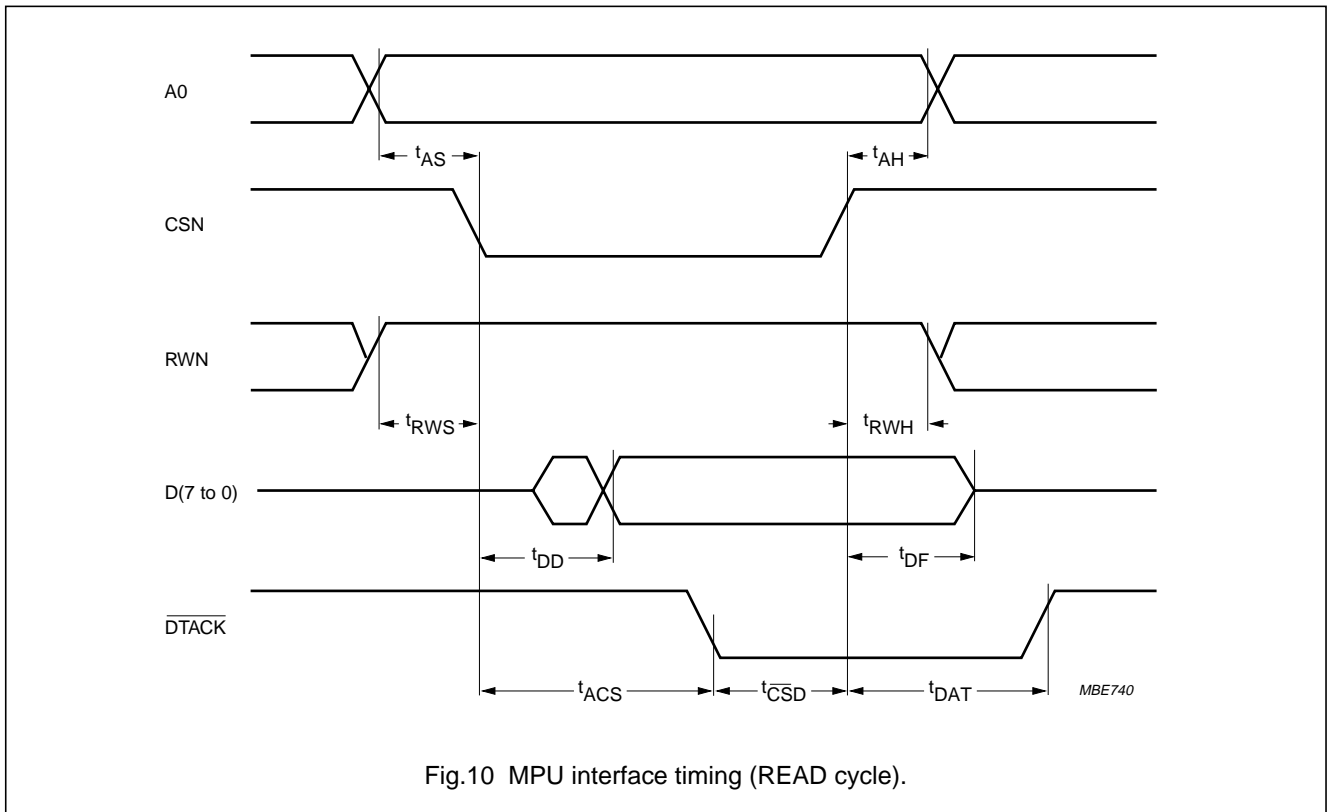
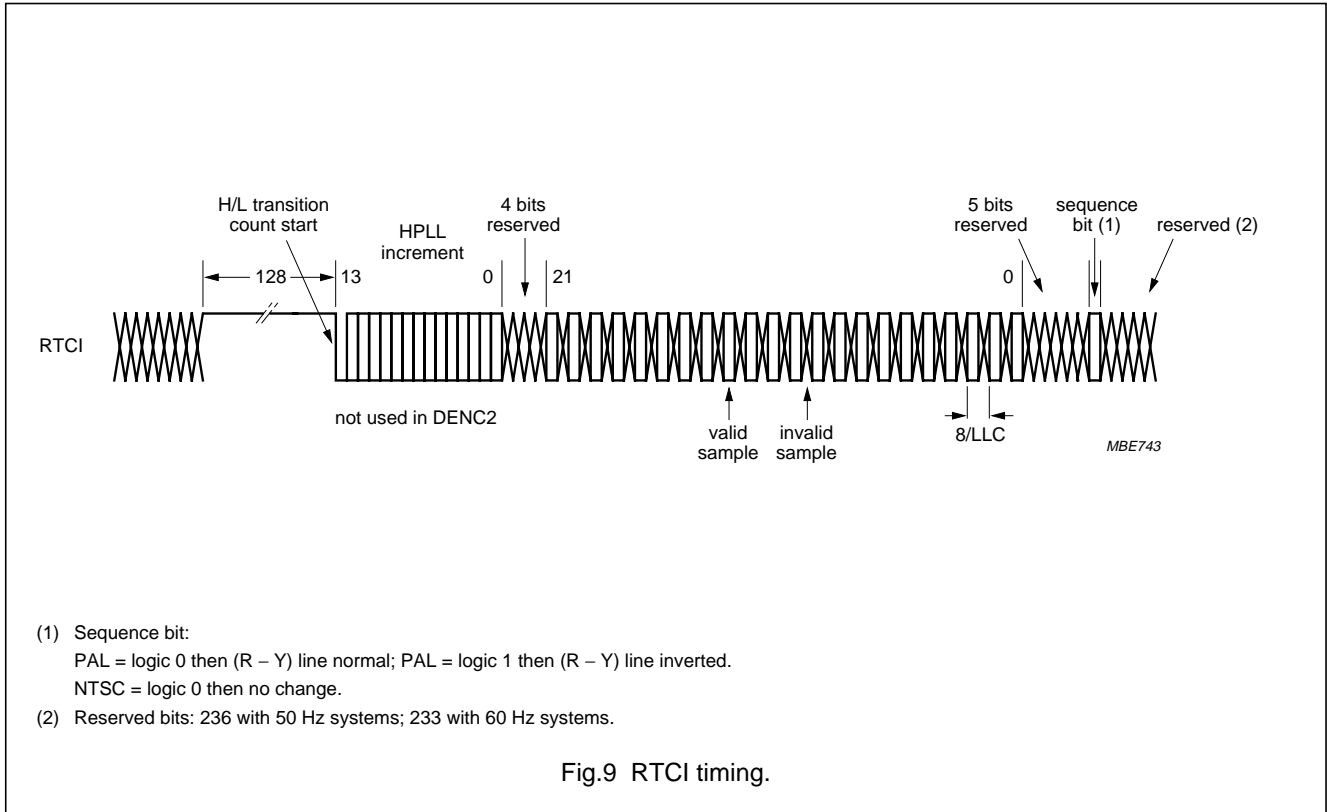

Digital Video Encoder (DENC2)

SAA7185

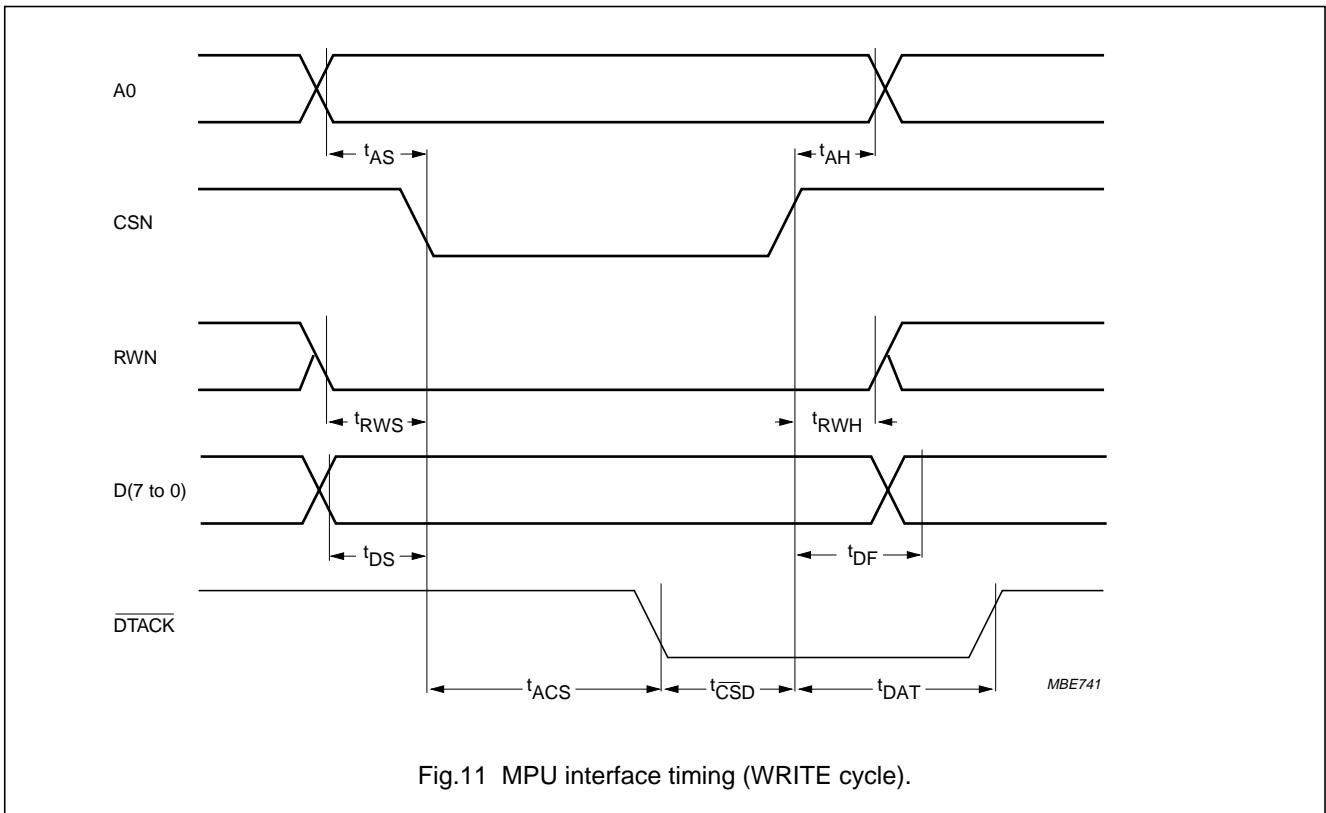

Digital Video Encoder (DENC2)

SAA7185

APPLICATION INFORMATION

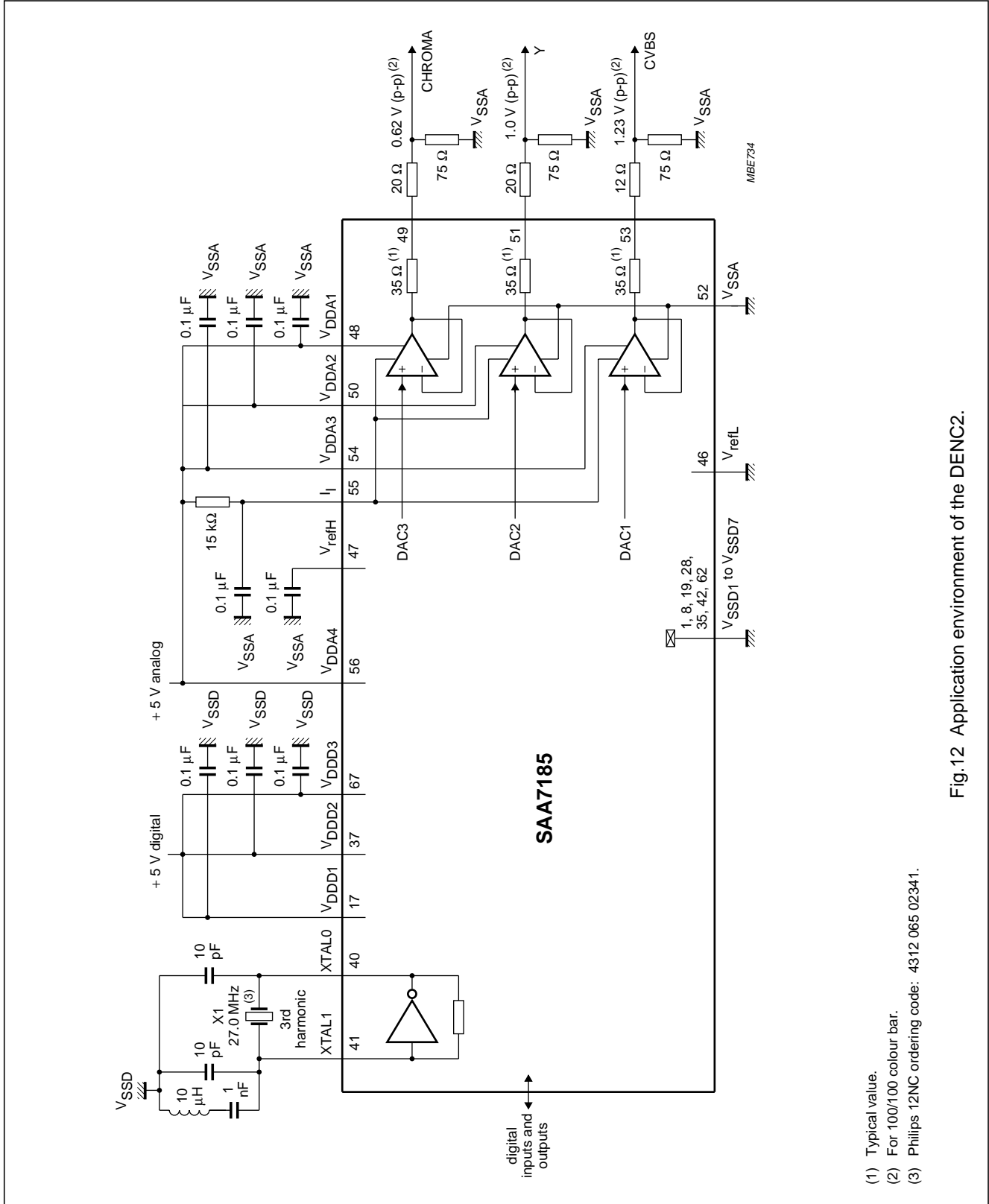

- (1) Typical value.
- (2) For 100/100 colour bar.
- (3) Philips 12NC ordering code: 4312 065 02341.

Fig.12 Application environment of the DENC2.

Digital Video Encoder (DENC2)

SAA7185

PACKAGE OUTLINE

PLCC68: plastic leaded chip carrier; 68 leads

SOT188-2

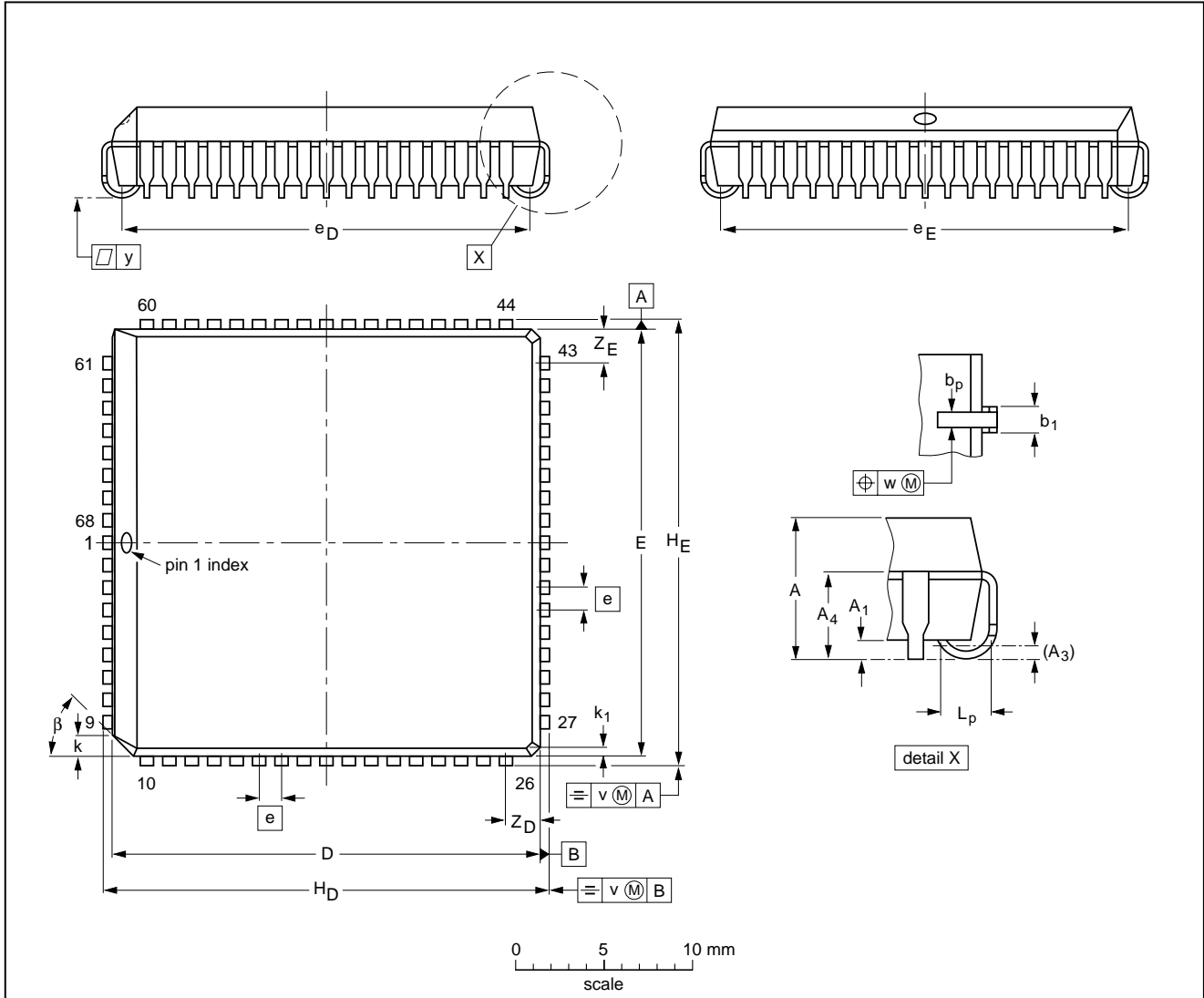

DIMENSIONS (millimetre dimensions are derived from the original inch dimensions)

UNIT	A	A ₁ min.	A ₃	A ₄ max.	b _p	b ₁	D ⁽¹⁾	E ⁽¹⁾	e	e _D	e _E	H _D	H _E	k	k ₁ max.	L _p	v	w	y	Z _D ⁽¹⁾ max.	Z _E ⁽¹⁾ max.	β
mm	4.57 4.19	0.51	0.25	3.30	0.53 0.33	0.81 0.66	24.33 24.13	24.33 24.13	1.27	23.62 22.61	23.62 22.61	25.27 25.02	25.27 25.02	1.22 1.07	0.51	1.44 1.02	0.18	0.18	0.10	2.16	2.16	45°
inches	0.180 0.165	0.020	0.01	0.13	0.021 0.013	0.032 0.026	0.958 0.950	0.958 0.950	0.05	0.930 0.890	0.930 0.890	0.995 0.985	0.995 0.985	0.048 0.042	0.020	0.057 0.040	0.007	0.007	0.004	0.085	0.085	

Note

1. Plastic or metal protrusions of 0.01 inches maximum per side are not included.

OUTLINE VERSION	REFERENCES				EUROPEAN PROJECTION	ISSUE DATE
	IEC	JEDEC	EIAJ			
SOT188-2	112E10	MO-047AC				92-11-17 95-03-11

Digital Video Encoder (DENC2)

SAA7185

SOLDERING

Introduction

There is no soldering method that is ideal for all IC packages. Wave soldering is often preferred when through-hole and surface mounted components are mixed on one printed-circuit board. However, wave soldering is not always suitable for surface mounted ICs, or for printed-circuits with high population densities. In these situations reflow soldering is often used.

This text gives a very brief insight to a complex technology. A more in-depth account of soldering ICs can be found in our *"IC Package Databook"* (order code 9398 652 90011).

Reflow soldering

Reflow soldering techniques are suitable for all PLCC packages.

The choice of heating method may be influenced by larger PLCC packages (44 leads, or more). If infrared or vapour phase heating is used and the large packages are not absolutely dry (less than 0.1% moisture content by weight), vaporization of the small amount of moisture in them can cause cracking of the plastic body. For more information, refer to the Drypack chapter in our *"Quality Reference Handbook"* (order code 9397 750 00192).

Reflow soldering requires solder paste (a suspension of fine solder particles, flux and binding agent) to be applied to the printed-circuit board by screen printing, stencilling or pressure-syringe dispensing before package placement.

Several techniques exist for reflowing; for example, thermal conduction by heated belt. Dwell times vary between 50 and 300 seconds depending on heating method. Typical reflow temperatures range from 215 to 250 °C.

Preheating is necessary to dry the paste and evaporate the binding agent. Preheating duration: 45 minutes at 45 °C.

Wave soldering

Wave soldering techniques can be used for all PLCC packages if the following conditions are observed:

- A double-wave (a turbulent wave with high upward pressure followed by a smooth laminar wave) soldering technique should be used.
- The longitudinal axis of the package footprint must be parallel to the solder flow.
- The package footprint must incorporate solder thieves at the downstream corners.

During placement and before soldering, the package must be fixed with a droplet of adhesive. The adhesive can be applied by screen printing, pin transfer or syringe dispensing. The package can be soldered after the adhesive is cured.

Maximum permissible solder temperature is 260 °C, and maximum duration of package immersion in solder is 10 seconds, if cooled to less than 150 °C within 6 seconds. Typical dwell time is 4 seconds at 250 °C.

A mildly-activated flux will eliminate the need for removal of corrosive residues in most applications.

Repairing soldered joints

Fix the component by first soldering two diagonally-opposite end leads. Use only a low voltage soldering iron (less than 24 V) applied to the flat part of the lead. Contact time must be limited to 10 seconds at up to 300 °C. When using a dedicated tool, all other leads can be soldered in one operation within 2 to 5 seconds between 270 and 320 °C.

Digital Video Encoder (DENC2)

SAA7185

DEFINITIONS

Data sheet status	
Objective specification	This data sheet contains target or goal specifications for product development.
Preliminary specification	This data sheet contains preliminary data; supplementary data may be published later.
Product specification	This data sheet contains final product specifications.
Limiting values	
Limiting values given are in accordance with the Absolute Maximum Rating System (IEC 134). Stress above one or more of the limiting values may cause permanent damage to the device. These are stress ratings only and operation of the device at these or at any other conditions above those given in the Characteristics sections of the specification is not implied. Exposure to limiting values for extended periods may affect device reliability.	
Application information	
Where application information is given, it is advisory and does not form part of the specification.	

LIFE SUPPORT APPLICATIONS

These products are not designed for use in life support appliances, devices, or systems where malfunction of these products can reasonably be expected to result in personal injury. Philips customers using or selling these products for use in such applications do so at their own risk and agree to fully indemnify Philips for any damages resulting from such improper use or sale.

PURCHASE OF PHILIPS I²C COMPONENTS



Purchase of Philips I²C components conveys a license under the Philips' I²C patent to use the components in the I²C system provided the system conforms to the I²C specification defined by Philips. This specification can be ordered using the code 9398 393 40011.

Digital Video Encoder (DENC2)

SAA7185

NOTES

Philips Semiconductors – a worldwide company

Argentina: see South America

Australia: 34 Waterloo Road, NORTH RYDE, NSW 2113,
Tel. +61 2 9805 4455, Fax. +61 2 9805 4466

Austria: Computerstr. 6, A-1101 WIEN, P.O. Box 213,
Tel. +43 1 60 101, Fax. +43 1 60 101 1210

Belarus: Hotel Minsk Business Center, Bld. 3, r. 1211, Volodarski Str. 6,
220050 MINSK, Tel. +375 172 200 733, Fax. +375 172 200 773

Belgium: see The Netherlands

Brazil: see South America

Bulgaria: Philips Bulgaria Ltd., Energoproject, 15th floor,
51 James Bourchier Blvd., 1407 SOFIA,
Tel. +359 2 689 211, Fax. +359 2 689 102

Canada: PHILIPS SEMICONDUCTORS/COMPONENTS,
Tel. +1 800 234 7381, Fax. +1 708 296 8556

China/Hong Kong: 501 Hong Kong Industrial Technology Centre,
72 Tat Chee Avenue, Kowloon Tong, HONG KONG,
Tel. +852 2319 7888, Fax. +852 2319 7700

Colombia: see South America

Czech Republic: see Austria

Denmark: Prags Boulevard 80, PB 1919, DK-2300 COPENHAGEN S,
Tel. +45 32 88 2636, Fax. +45 31 57 1949

Finland: Sinikalliontie 3, FIN-02630 ESPOO,
Tel. +358 615 800, Fax. +358 615 80920

France: 4 Rue du Port-aux-Vins, BP317, 92156 SURESNES Cedex,
Tel. +33 1 40 99 6161, Fax. +33 1 40 99 6427

Germany: Hammerbrookstraße 69, D-20097 HAMBURG,
Tel. +49 40 23 52 60, Fax. +49 40 23 536 300

Greece: No. 15, 25th March Street, GR 17778 TAVROS,
Tel. +30 1 4894 339/911, Fax. +30 1 4814 240

Hungary: see Austria

India: Philips INDIA Ltd, Shivsagar Estate, A Block, Dr. Annie Besant Rd.
Worli, MUMBAI 400 018, Tel. +91 22 4938 541, Fax. +91 22 4938 722

Indonesia: see Singapore

Ireland: Newstead, Clonskeagh, DUBLIN 14,
Tel. +353 1 7640 000, Fax. +353 1 7640 200

Israel: RAPAC Electronics, 7 Kehilat Saloniki St, TEL AVIV 61180,
Tel. +972 3 645 0444, Fax. +972 3 648 1007

Italy: PHILIPS SEMICONDUCTORS, Piazza IV Novembre 3,
20124 MILANO, Tel. +39 2 6752 2531, Fax. +39 2 6752 2557

Japan: Philips Bldg 13-37, Kohnan 2-chome, Minato-ku, TOKYO 108,
Tel. +81 3 3740 5130, Fax. +81 3 3740 5077

Korea: Philips House, 260-199 Itaewon-dong, Yongsan-ku, SEOUL,
Tel. +82 2 709 1412, Fax. +82 2 709 1415

Malaysia: No. 76 Jalan Universiti, 46200 PETALING JAYA, SELANGOR,
Tel. +60 3 750 5214, Fax. +60 3 757 4880

Mexico: 5900 Gateway East, Suite 200, EL PASO, TEXAS 79905,
Tel. +1 800 234 7381, Fax. +1 708 296 8556

Middle East: see Italy

Netherlands: Postbus 90050, 5600 PB EINDHOVEN, Bldg. VB,
Tel. +31 40 27 83749, Fax. +31 40 27 88399

New Zealand: 2 Wagener Place, C.P.O. Box 1041, AUCKLAND,
Tel. +64 9 849 4160, Fax. +64 9 849 7811

Norway: Box 1, Manglerud 0612, OSLO,
Tel. +47 22 74 8000, Fax. +47 22 74 8341

Philippines: Philips Semiconductors Philippines Inc.,
106 Valero St. Salcedo Village, P.O. Box 2108 MCC, MAKATI,
Metro MANILA, Tel. +63 2 816 6380, Fax. +63 2 817 3474

Poland: Ul. Lukiska 10, PL 04-123 WARSZAWA,
Tel. +48 22 612 2831, Fax. +48 22 612 2327

Portugal: see Spain

Romania: see Italy

Russia: Philips Russia, Ul. Usatcheva 35A, 119048 MOSCOW,
Tel. +7 095 926 5361, Fax. +7 095 564 8323

Singapore: Lorong 1, Toa Payoh, SINGAPORE 1231,
Tel. +65 350 2538, Fax. +65 251 6500

Slovakia: see Austria

Slovenia: see Italy

South Africa: S.A. PHILIPS Pty Ltd., 195-215 Main Road Martindale,
2092 JOHANNESBURG, P.O. Box 7430 Johannesburg 2000,
Tel. +27 11 470 5911, Fax. +27 11 470 5494

South America: Rua do Rocio 220, 5th floor, Suite 51,
04552-903 São Paulo, SÃO PAULO - SP, Brazil,
Tel. +55 11 821 2333, Fax. +55 11 829 1849

Spain: Balmes 22, 08007 BARCELONA,
Tel. +34 3 301 6312, Fax. +34 3 301 4107

Sweden: Kottbygatan 7, Akalla, S-16485 STOCKHOLM,
Tel. +46 8 632 2000, Fax. +46 8 632 2745

Switzerland: Allmendstrasse 140, CH-8027 ZÜRICH,
Tel. +41 1 488 2686, Fax. +41 1 481 7730

Taiwan: PHILIPS TAIWAN Ltd., 23-30F, 66,
Chung Hsiao West Road, Sec. 1, P.O. Box 22978,
TAIPEI 100, Tel. +886 2 382 4443, Fax. +886 2 382 4444

Thailand: PHILIPS ELECTRONICS (THAILAND) Ltd.,
209/2 Sanpavuth-Bangna Road Prakanong, BANGKOK 10260,
Tel. +66 2 745 4090, Fax. +66 2 398 0793

Turkey: Talatpasa Cad. No. 5, 80640 GÜLTEPE/ISTANBUL,
Tel. +90 212 279 2770, Fax. +90 212 282 6707

Ukraine: PHILIPS UKRAINE, 2A Akademika Koroleva str., Office 165,
252148 KIEV, Tel. +380 44 476 0297/1642, Fax. +380 44 476 6991

United Kingdom: Philips Semiconductors Ltd., 276 Bath Road, Hayes,
MIDDLESEX UB3 5BX, Tel. +44 181 730 5000, Fax. +44 181 754 8421

United States: 811 East Arques Avenue, SUNNYVALE, CA 94088-3409,
Tel. +1 800 234 7381, Fax. +1 708 296 8556

Uruguay: see South America

Vietnam: see Singapore

Yugoslavia: PHILIPS, Trg N. Pasica 5/v, 11000 BEOGRAD,
Tel. +381 11 825 344, Fax. +381 11 635 777

For all other countries apply to: Philips Semiconductors, Marketing & Sales Communications, Building BE-p, P.O. Box 218, 5600 MD EINDHOVEN, The Netherlands, Fax. +31 40 27 24825

Internet: <http://www.semiconductors.philips.com/ps/>

© Philips Electronics N.V. 1996

SCA50

All rights are reserved. Reproduction in whole or in part is prohibited without the prior written consent of the copyright owner.

The information presented in this document does not form part of any quotation or contract, is believed to be accurate and reliable and may be changed without notice. No liability will be accepted by the publisher for any consequence of its use. Publication thereof does not convey nor imply any license under patent- or other industrial or intellectual property rights.

Printed in The Netherlands

657021/1200/02/pp36

Date of release: 1996 Jul 08

Document order number: 9397 750 00943

Let's make things better.

Philips
Semiconductors



PHILIPS